



SEGM/WR - BPQ - WR/SEGM

Length : 132.34 Kms

| | Section | Ruling Gradient | Length |
|----|------------|-----------------|----------|
| UP | WRR - CKNI | 1/150 | 1.00 Kms |
| UP | HGT - WG | 1/150 | 3.25 Kms |
| DN | YNA - NGI | 1/135 | 1.94 Kms |
| DN | NGI - CKNI | 1/140 | 2.96 Kms |

Designed & Prepared by - V K Gupta, CLI/NGP

BHUGAON (BPK)

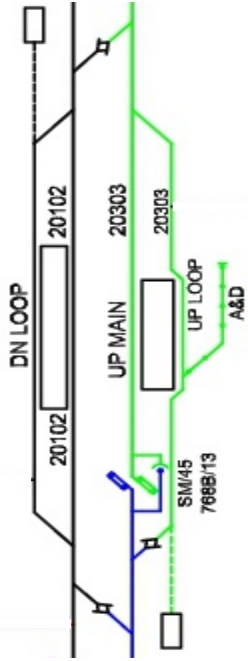

SONEGAON (SNN)

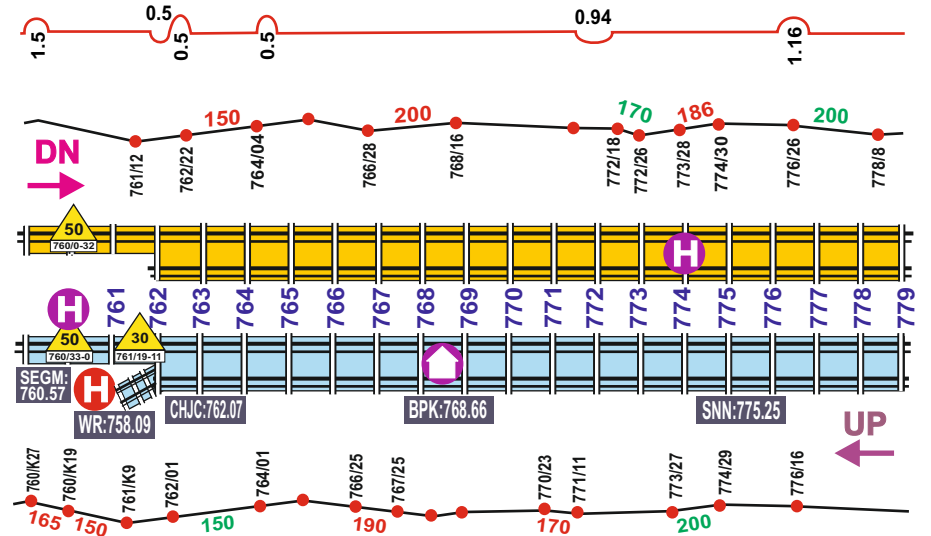
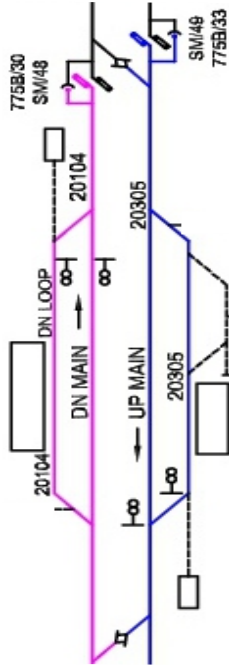

- H Home signal restricted
- H Home signal restricted (proposed)
- S Station restricted(Proposed)
- S Station restricted
- G Gate signal restricted

WAGHOLI (WG)

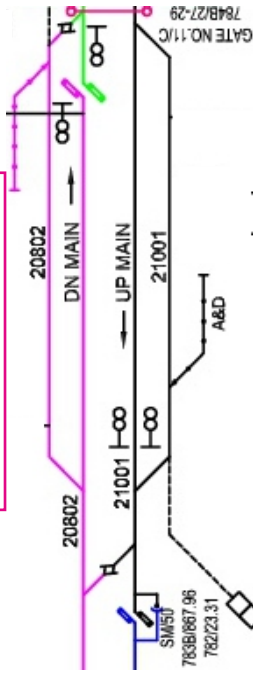

HINGANGHAT (HGT)

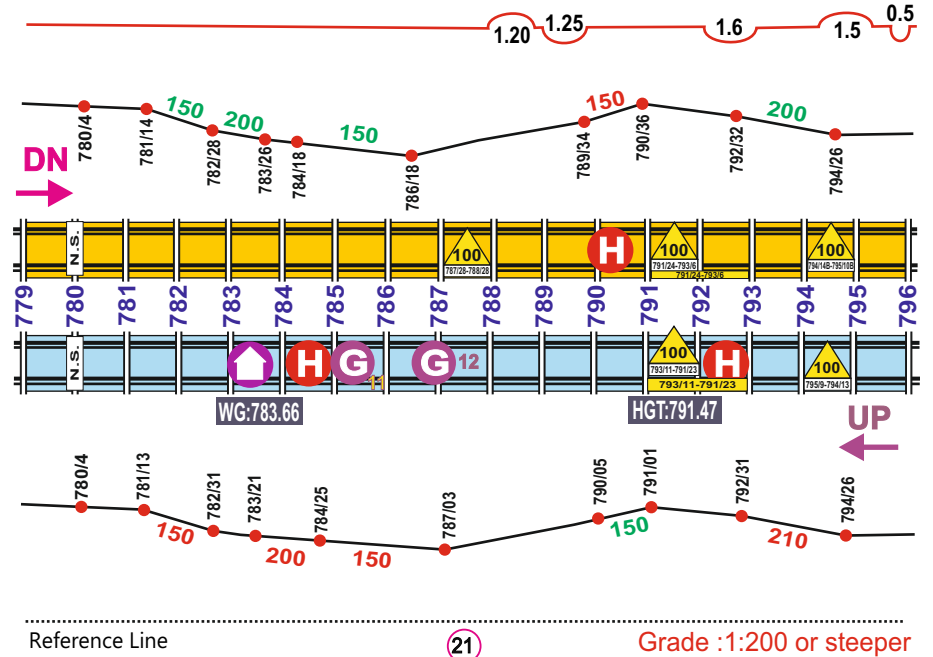
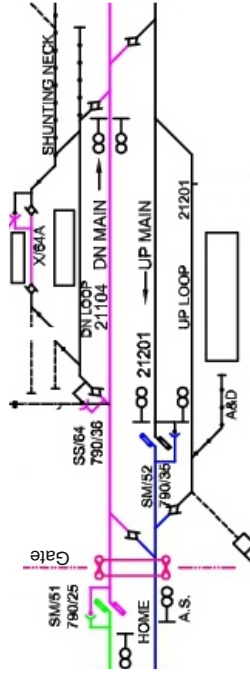

NAGRI (NGI)

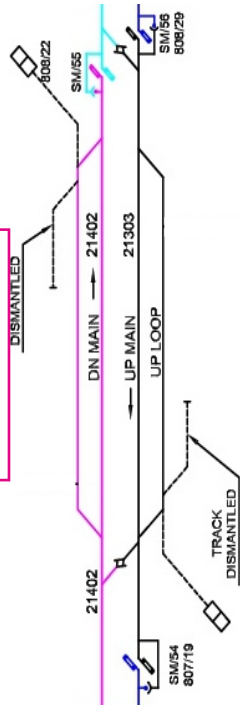

WANI (WUN)

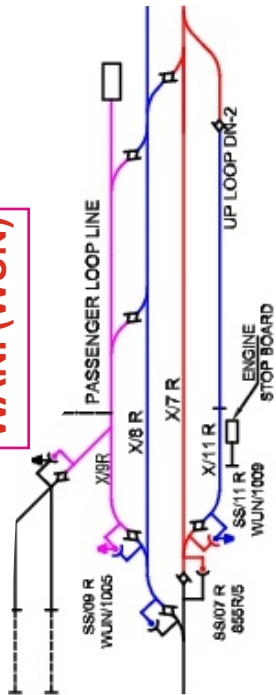

RAJUR (RAJR)

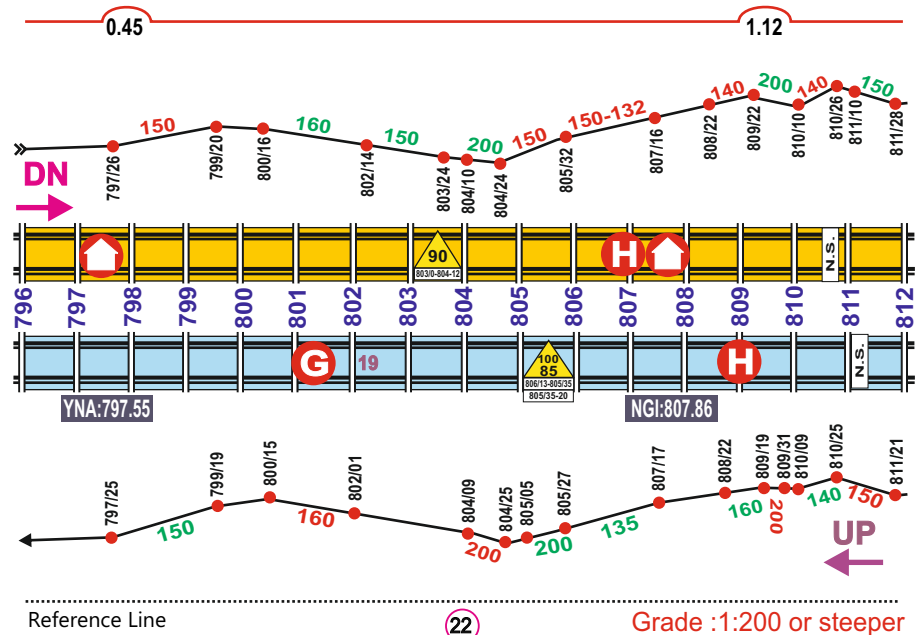
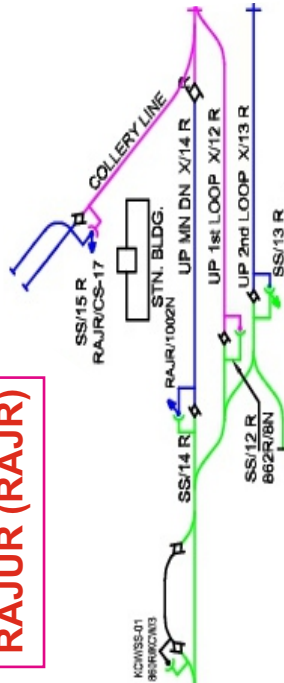

CHIKNI ROAD (CKNI)

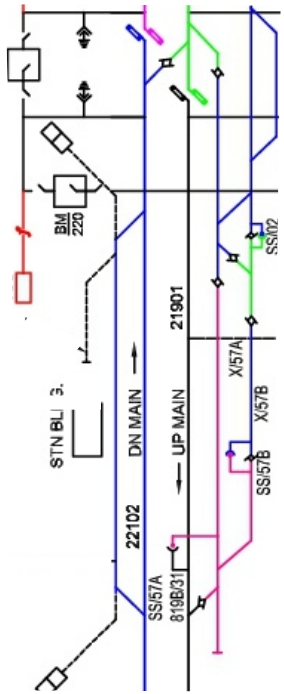

GGG SDG. & DHARIWAL SDG.

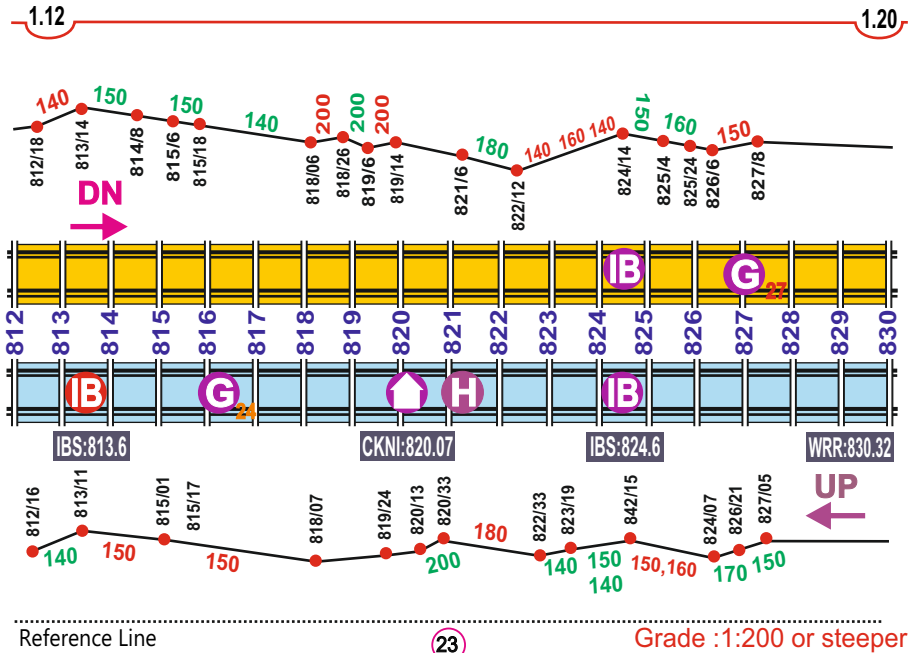
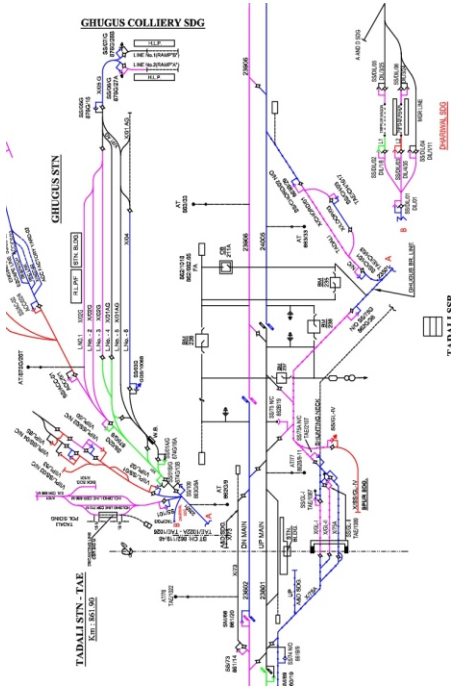

WARORA (WRR)

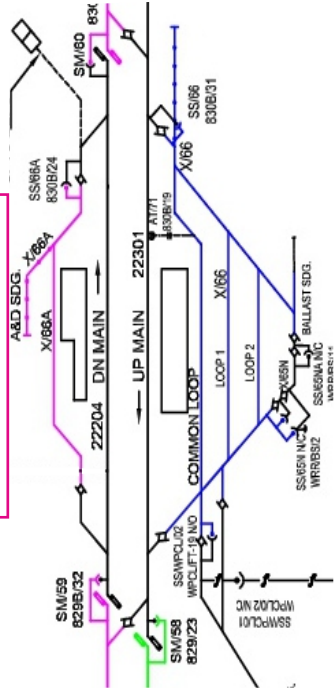

MAJRI (MJRI)

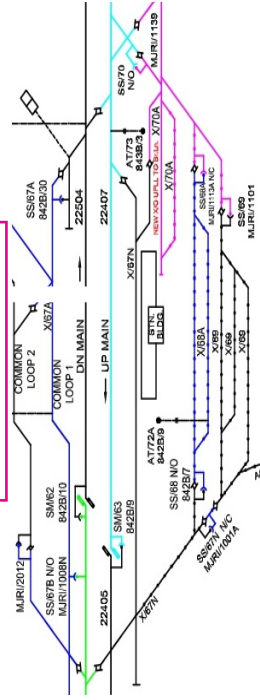

MAJRI KHADAN (MJKN)

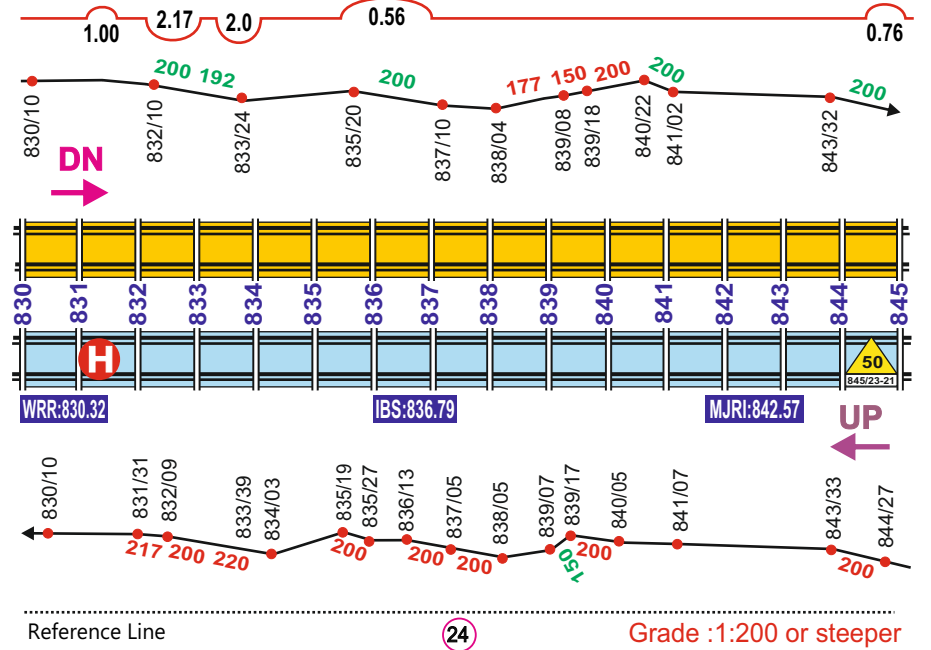
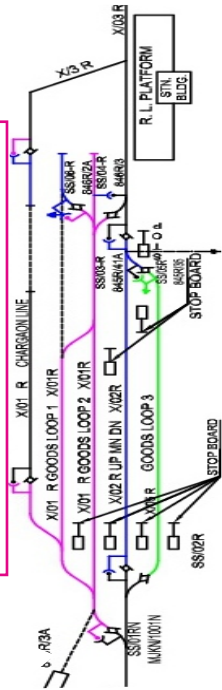

BHANDHAK (BUX)

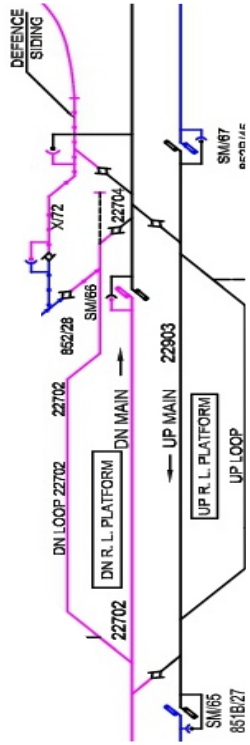

MSEB SDG

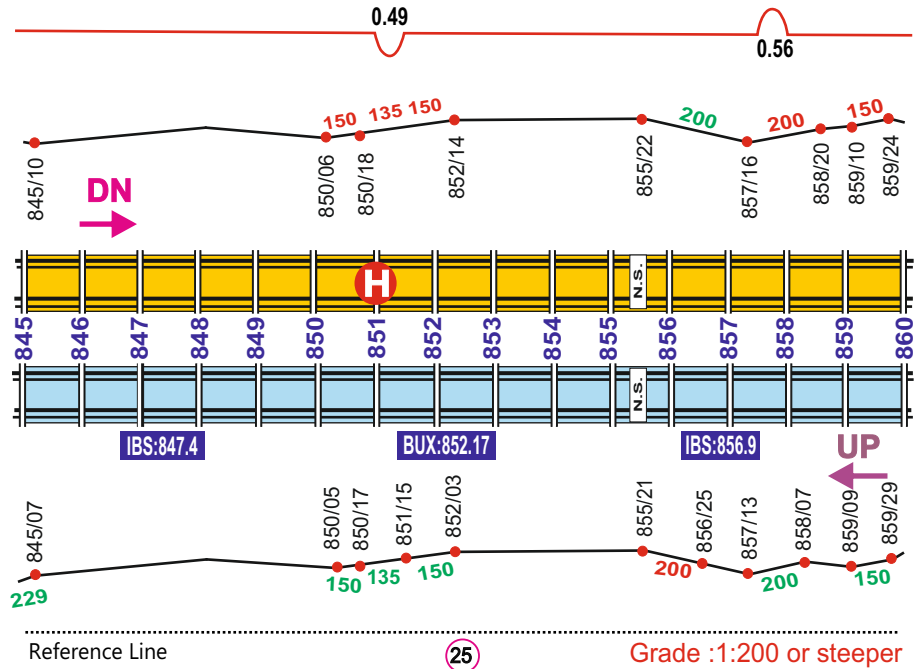
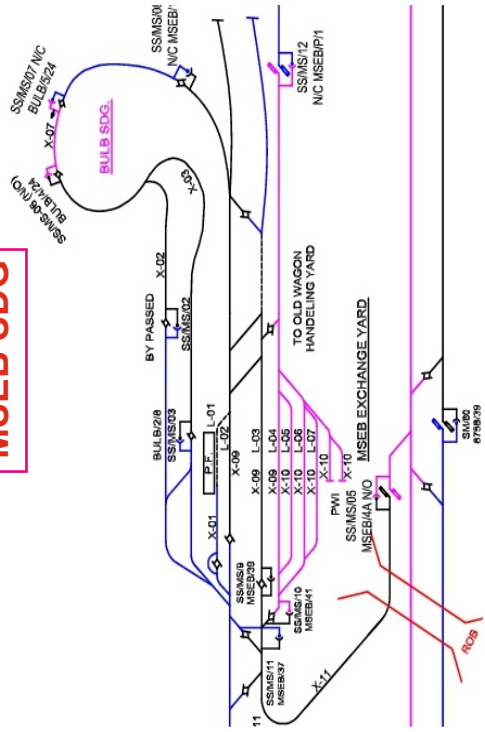

CHANDRAPUR (CD)

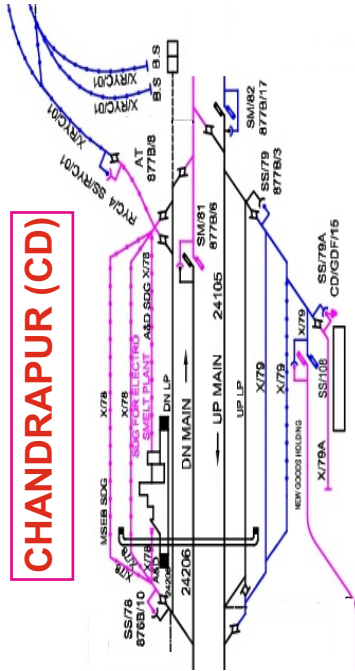

BABUPETH (BUPH)

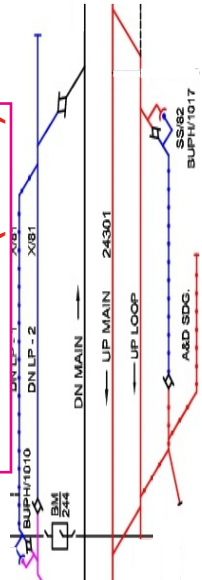

BALHARSHAH (BPQ)

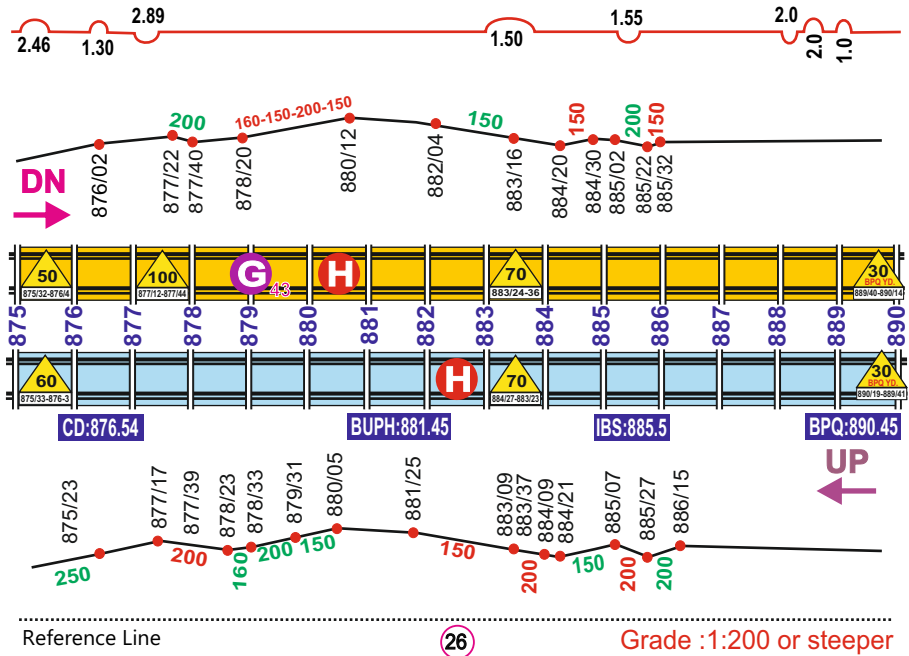
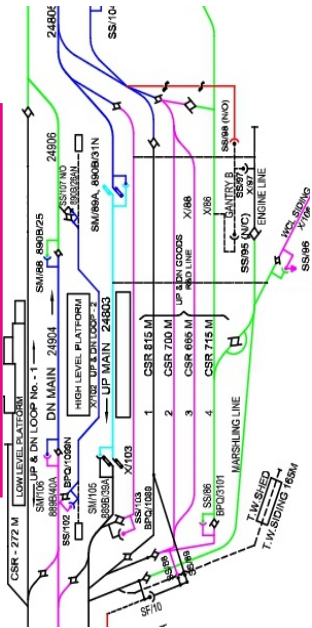

TADALI (TAE)

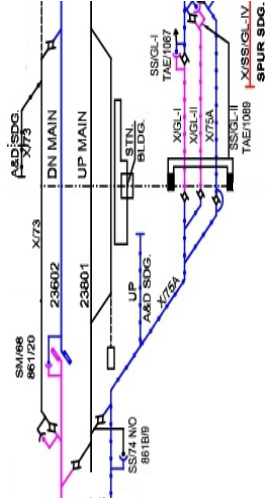

CHOTI PADOLI (CPW)

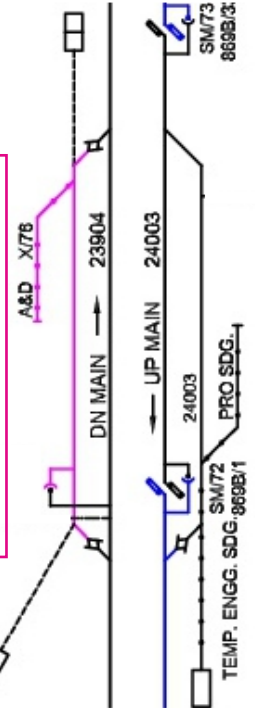

VIVEKANAND NAGAR (VVKN)

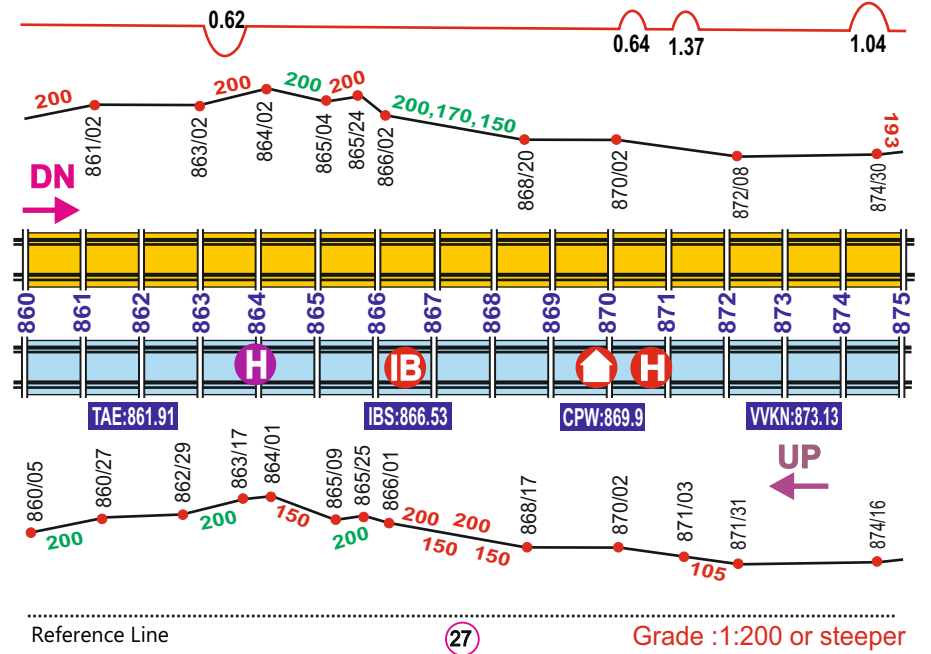
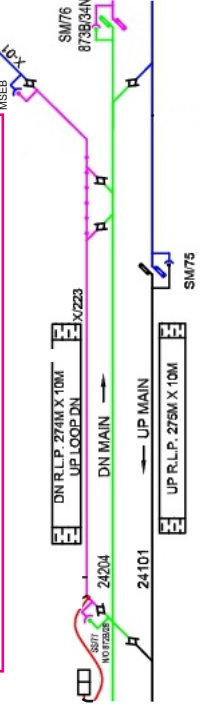

Reference Line

27

Grade :1:200 or steeper



NRKR - BD - NRKR

Single Line

Length : 95.43 + 42.88 = 138.31 Kms

| | Section | Ruling Gradient | Length |
|----|------------|-----------------|--------|
| UP | PUSA-WOC | 1/171 | 0.51 |
| DN | CNDB - WOC | 1/150 | 3.863 |

Designed & Prepared by - V K Gupta, CLI/NGP

NARKHED (NRKR)

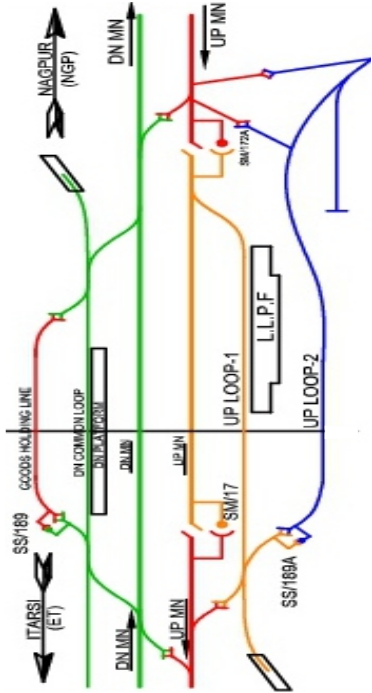

PUSLA (PUSA)

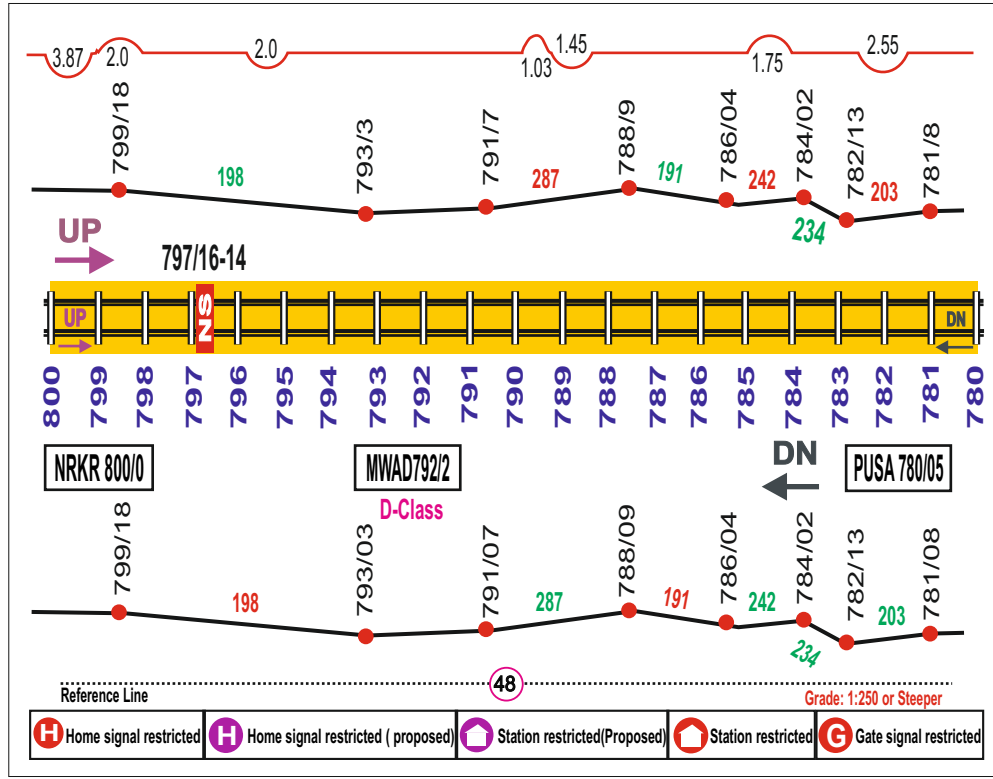

WARUD ORANGE CITY (WOC)

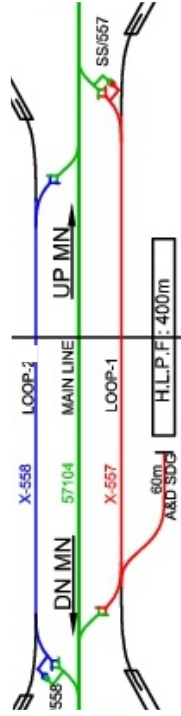

MORSHI (MRSH)

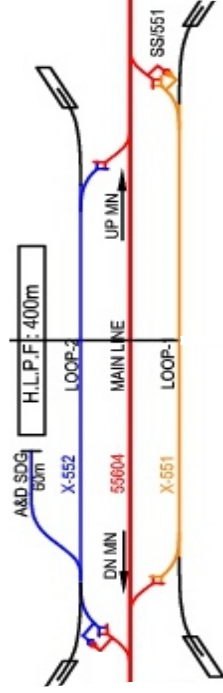

CHANDUR BAZAR (CNDB)

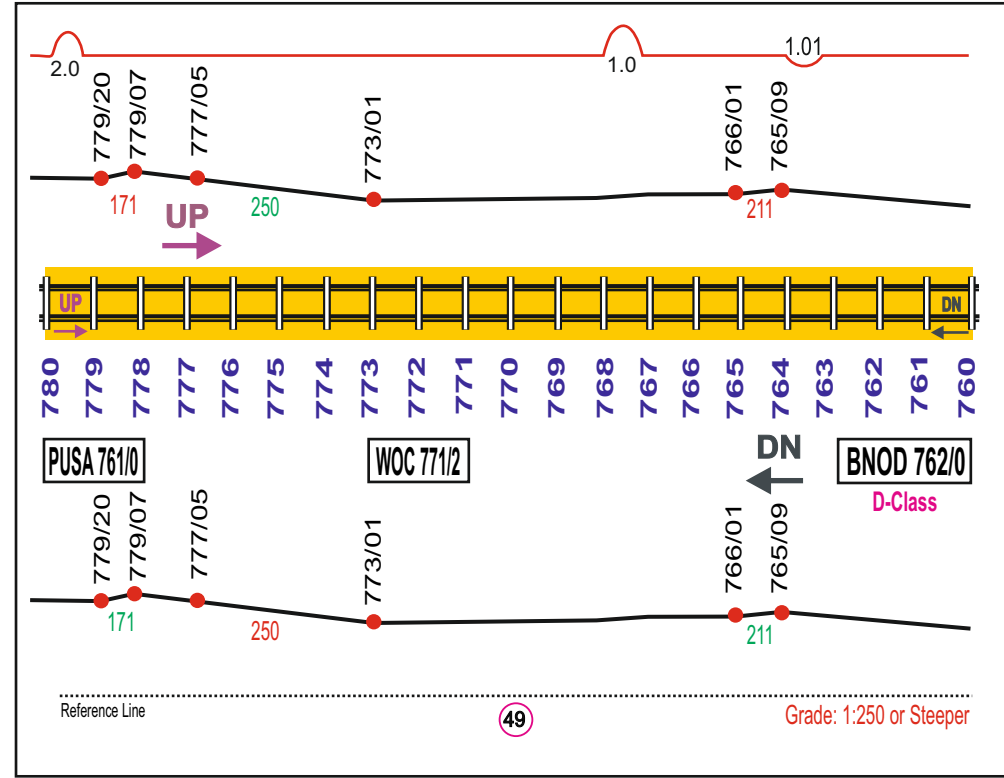
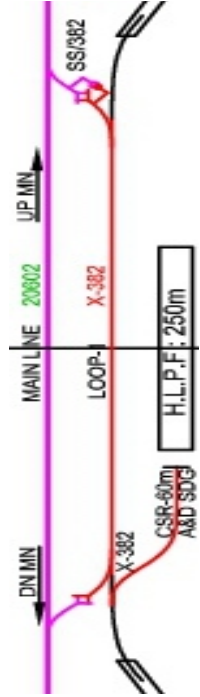

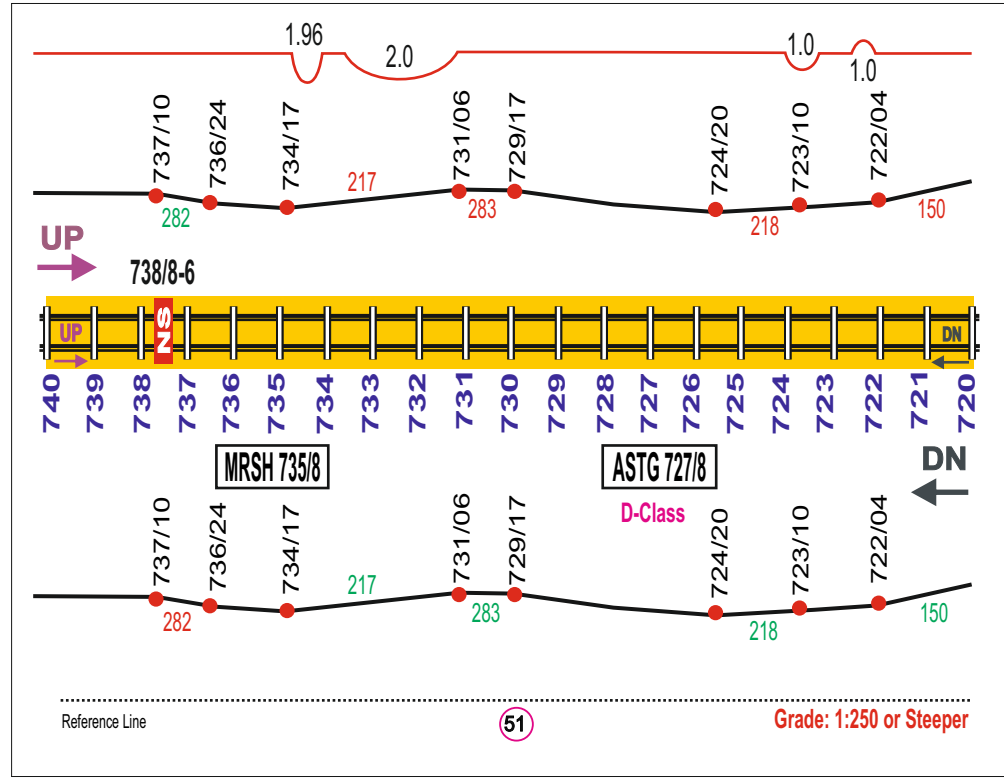
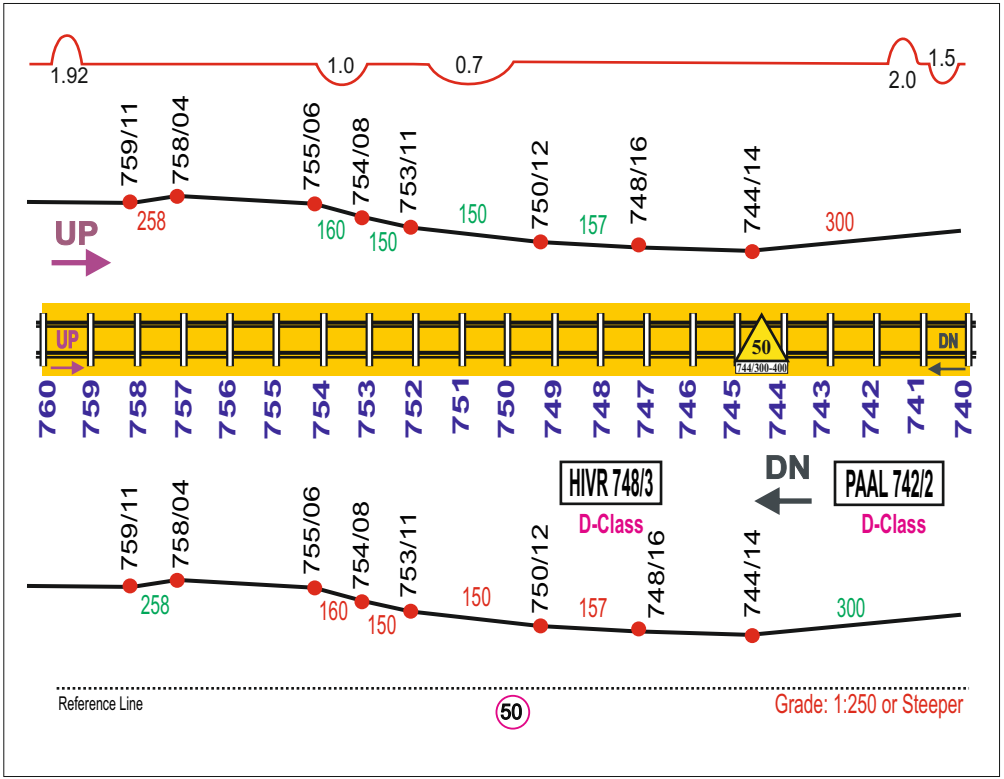

WALGAON (WLGN)

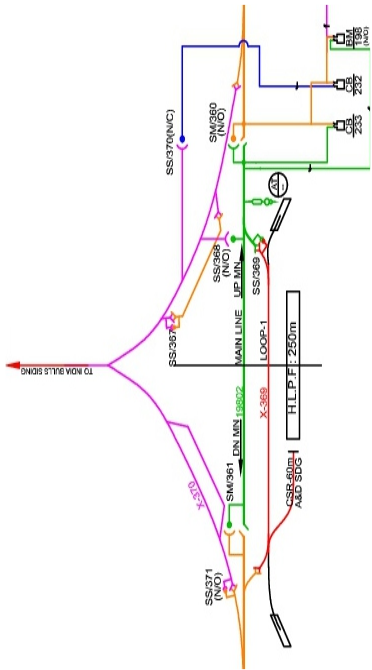

NEW AMRAVATI (AMI)

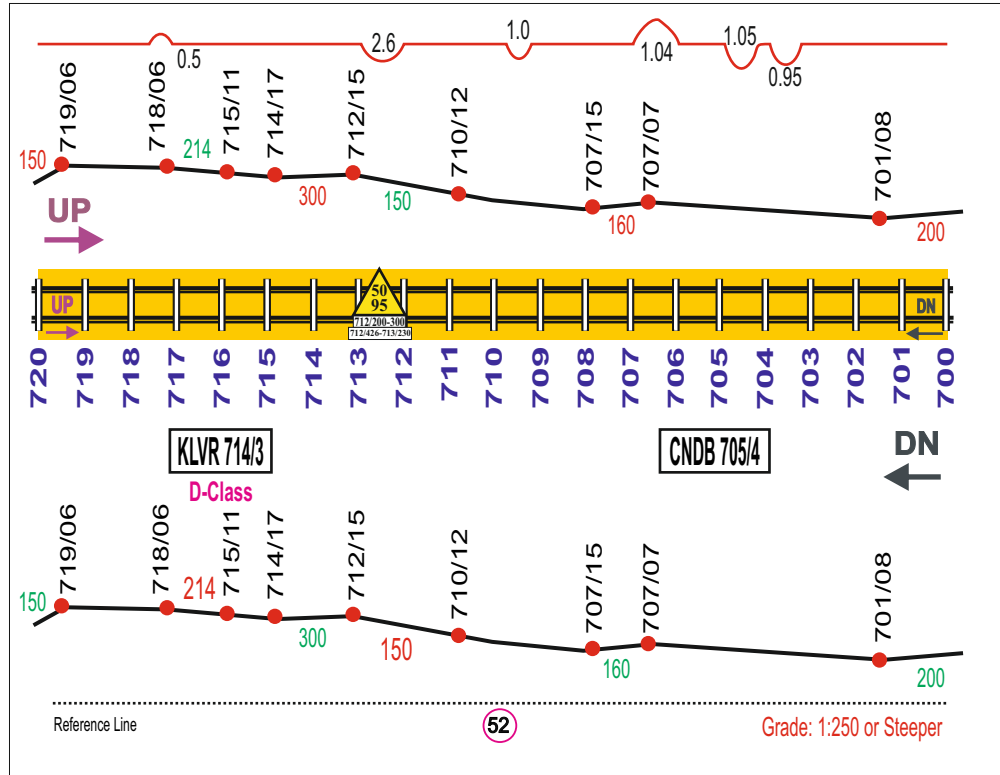
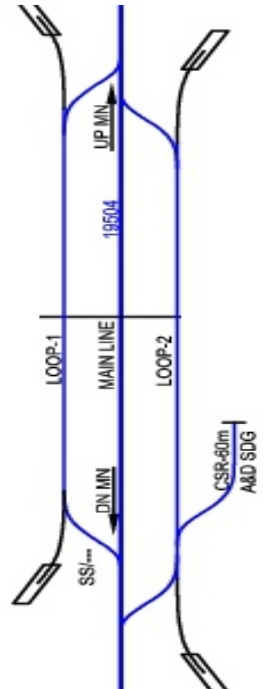

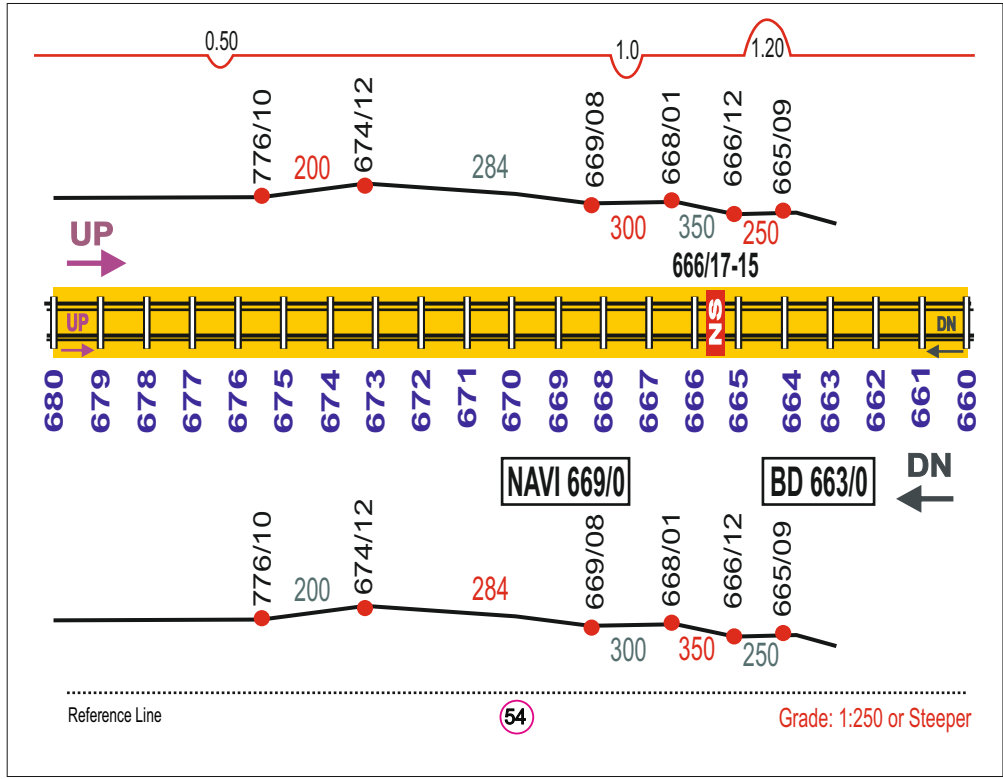
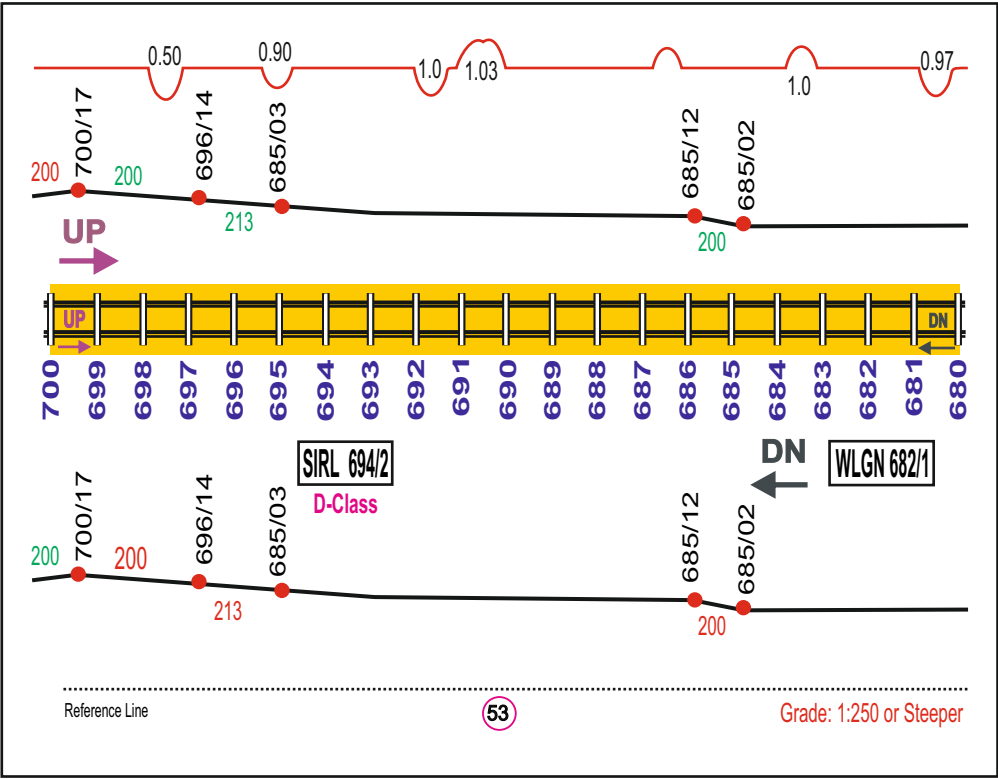

प्रतिबंधित सिग्नल एवं स्टेशन
(As per WTT-102)

ET-AMLA: Home signal of KRTH, KSLA, GDYA, DHQ, BYS & JHP. GDYA , DHQ stations & IBH between GDYA-DHQ, BYS-AMF.

AMLA-ET: Home signal of DOH & DOH Station. Gate No. 232 (KQE-SALI).

NGP-AMLA: Home signal of GNQ,SNKB, MER, DDMT, HTN, AMF & BWRA Loop line, SNKB & AMF Stn. and IBH between KSWR-KOHL,KOHL- SNKB, SNKB-MER & NRKR-DDMT.

AMLA- NGP: Home signal of JKR, TNH, KLBA, KATL, MER, PAR. IBH bet. AMF-JKR, JKR-MTY, PAR-DDMT & MTY stn.

NGP- BD: Home signal of KRI ,GMG, TGP, SEGM, WR,DAE,DMN,DIP & MLR. IBH between SLOR-SEGM, WR-DAE, CND-MLR & Loop line at PLO & DMN station, Gate No. 109 (BTBR-BOK).

BD- NGP: Home signal of TMT,CND,WR, BOK, GMG , KRI, PLO & BOK Stn. & IBH (SLOR-TGP).

BPQ-SEGM/WR: Home signal of BUPH, CPW, WG, SEGM/WR, IBH(CPW-TAE), IBH(CKNI-NGI) & CPW station, Gate No.19 (NGI-YNA).

SEGM/WR- BPQ: Home signal of HGT, NGI, BUPH, BUX & YNA, NGI Station. 55

IBS, Home Signal Located on raising gradients indicating section, location, gradient, length of gradient etc.

(Ref: As per WTT-102 , Page No. G-27)

| सेक्शन | लोकेशन | ग्रेडियेंट | | ग्रेडियेंट की लम्बाई | ग्रेड |
|-----------|------------|------------|---------|----------------------|-------|
| | | से | तक | | |
| MLR-CND | CND H/Sig. | 689.14 | 692.80 | 3.70 | 1:150 |
| SLOR-TGP | IBH | 774.70 | 777.19 | 2.80 | 1:150 |
| BTBR-GMG | GMG H/Sig. | 812.22 | 818.20 | 5.82 | 1:150 |
| BTBR-BOK | Gate-109 | 809.05 | 803.11 | 6.10 | 1:150 |
| CHJC-WR | WR H/Sig. | 761.09 | 760.02 | 1.09 | 1:150 |
| KSWR-KOHL | IBH | 1015.23 | 1009.15 | 6.18 | 1:150 |
| KOHL-SNKB | IBH | 1003.11 | 998.33 | 4.35 | 1:150 |
| SNKB-MER | IBH | 997.19 | 992.10 | 5.40 | 1:150 |
| NRKR-DDMT | IBH | 953.90 | 947.15 | 5.88 | 1:150 |
| PAR-DDMT | PAR H/Sig. | 937.22 | 940.10 | 2.91 | 1:150 |
| BYS-AMLA | IBH | 865.24 | 873.18 | 7.70 | 1:150 |

Please note that Loco & Load combination for which through signal condition is required as under:-
WAG5 (SU) - 35 BOX/BCX/BFK/BRH/BTAL/32BTBG loaded above 3000T & WAG-7/9 (SU)-45 BLC/ 43 BCNA / BOST / BRN / BFNS / 42BCN / BCCW/40BLL /BOX-N / 50 BTPN loaded and 59 BOXN / 58 BCNH loaded above 4000T.

56

This has the approval of COM. **Designed & Prepared by - V K Gupta, CLI/NGP**



NGP - BD - NGP

Length : 174.02 Kms

| | Section | Ruling Gradient | Length |
|----|------------|-----------------|-----------|
| UP | TGP - SLOR | 1/130 | 0.195 Kms |
| UP | CND - MLR | 1/150 | 2.81 Kms |
| DN | DAE - WR | 1/132 | 1.90 Kms |
| DN | GMG - KRI | 1/130 | 0.110 Kms |

KHAPRI (KRI)

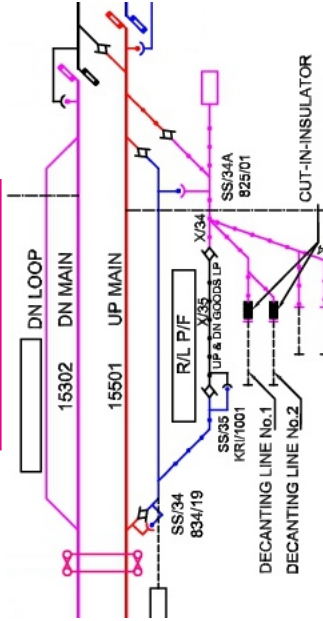

GUMGAON (GMG)

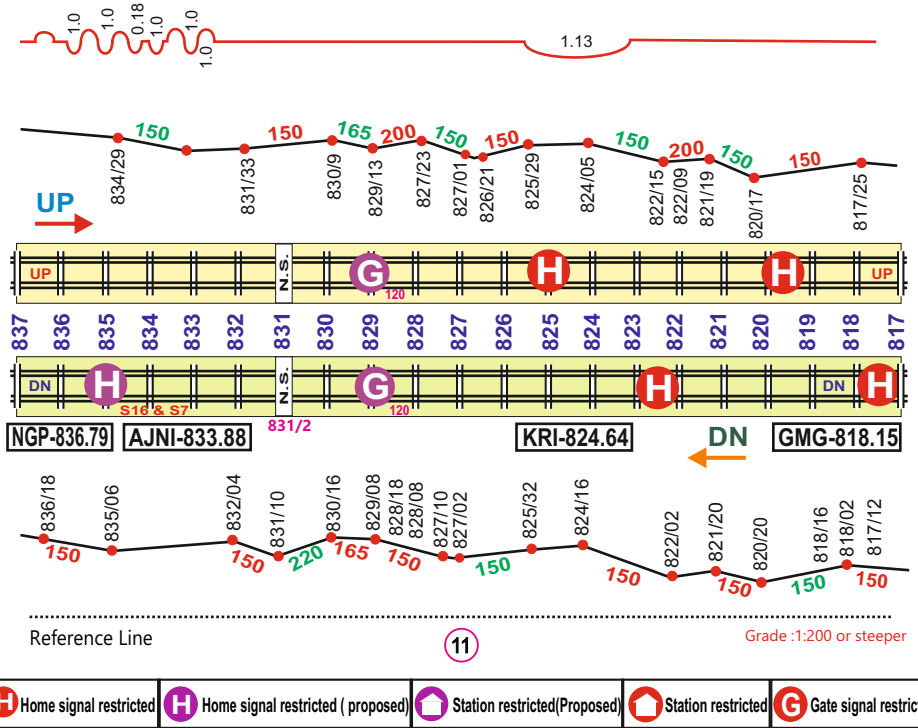
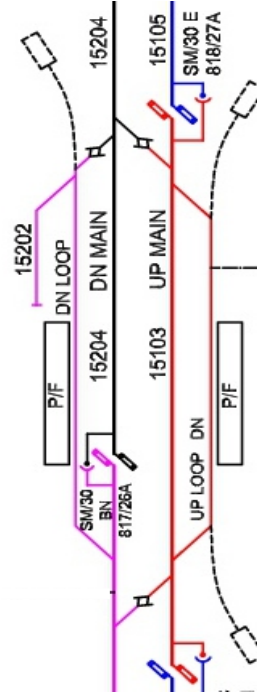

BUTIBORI (BTBR)

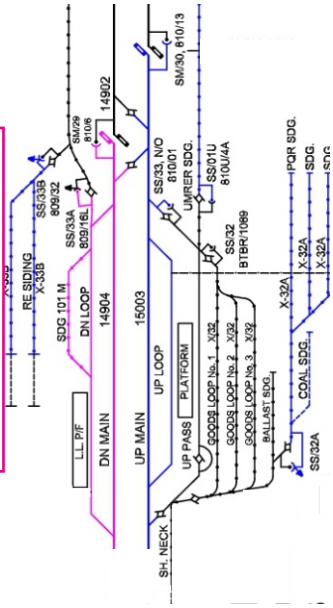

UMRER SDG. (URSG)

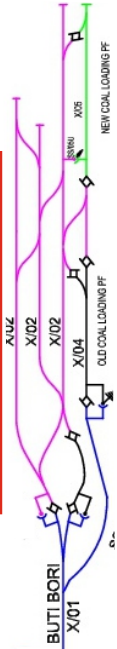

BORKHEDI (BOK)

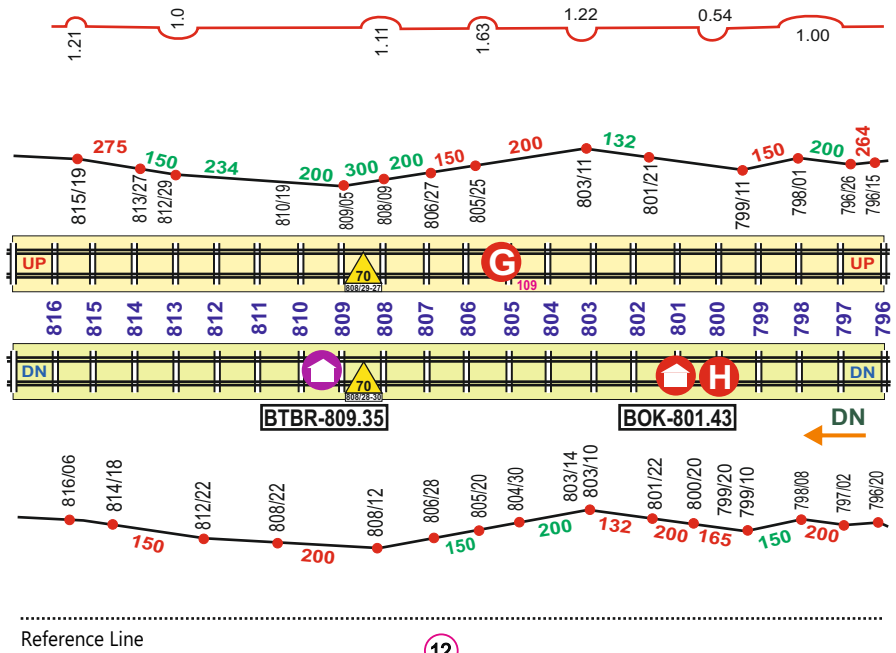
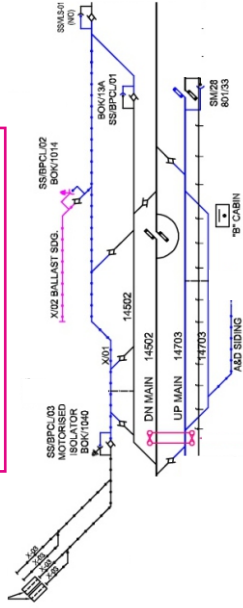

SINDI (SNI)

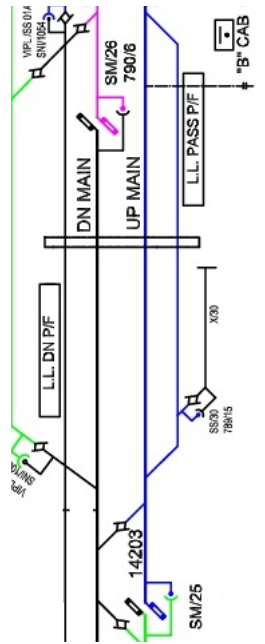

TULJAPUR (TJP)

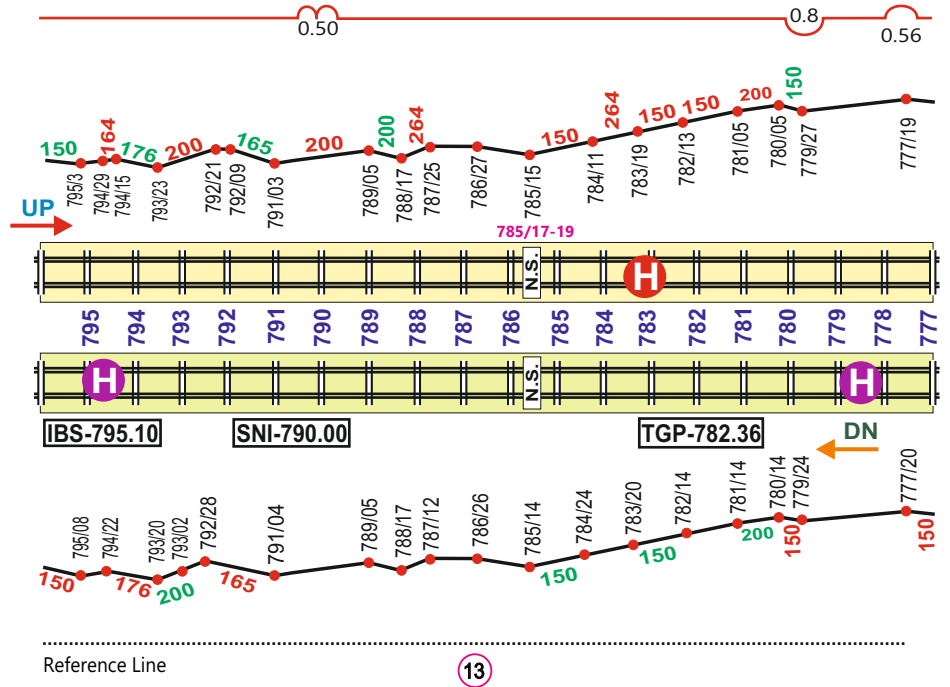
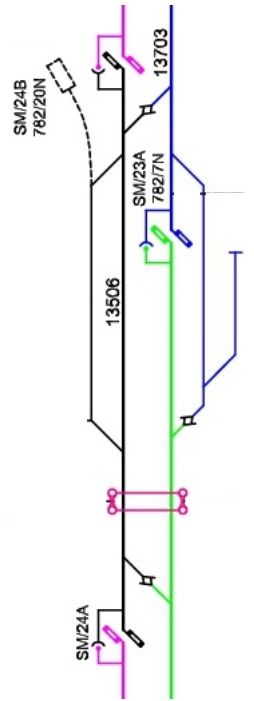

WARDHA (WR)

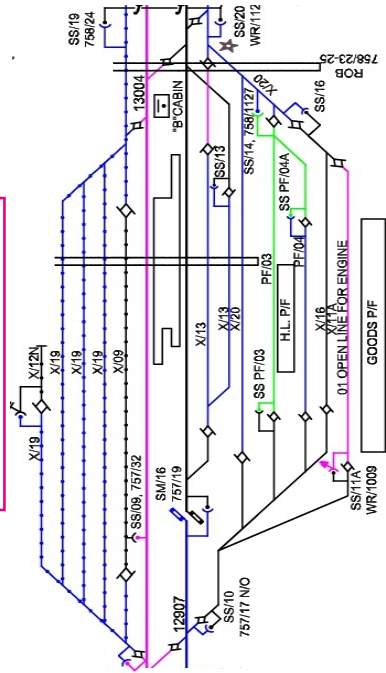

DAHEGAON (DAE)

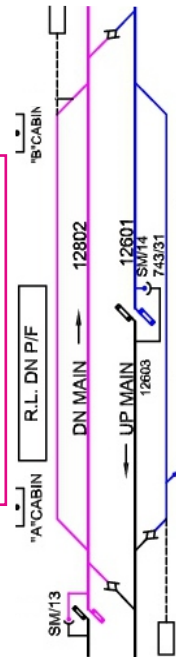

KAOTHA (KAOT)

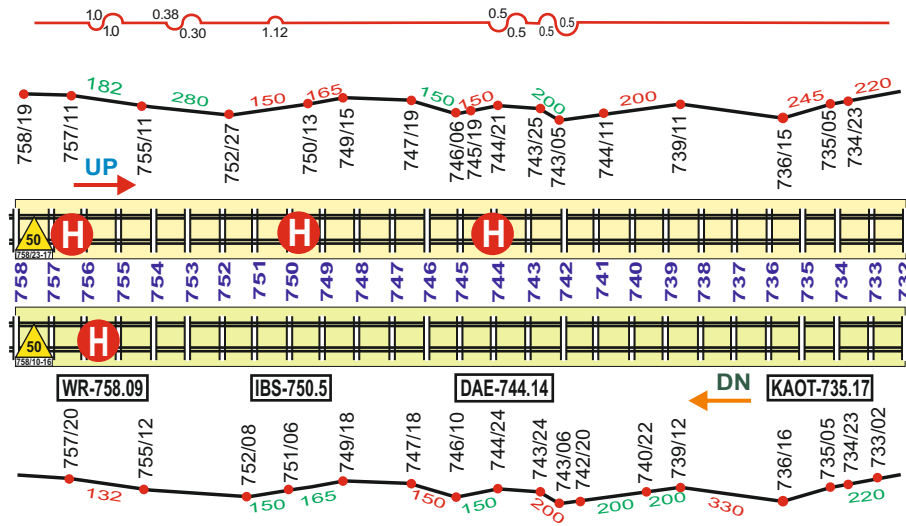
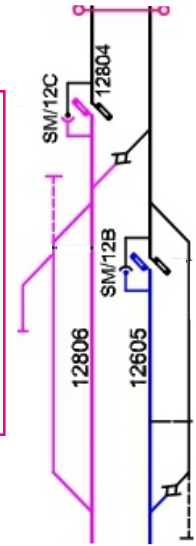

Reference Line

PULGAON (PLO)

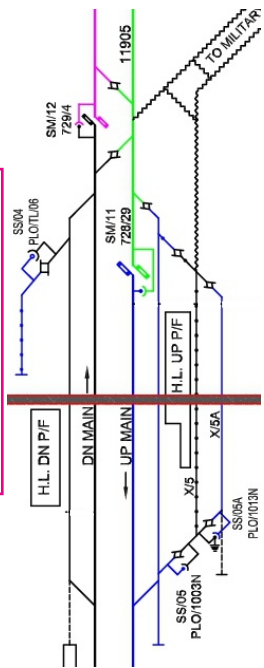

DHAMANGAON (DMN)

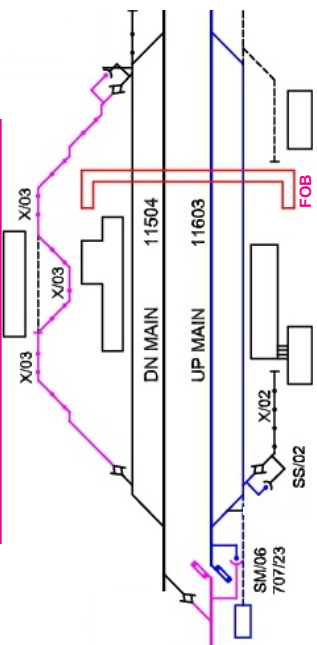

CHANDUR (CND)

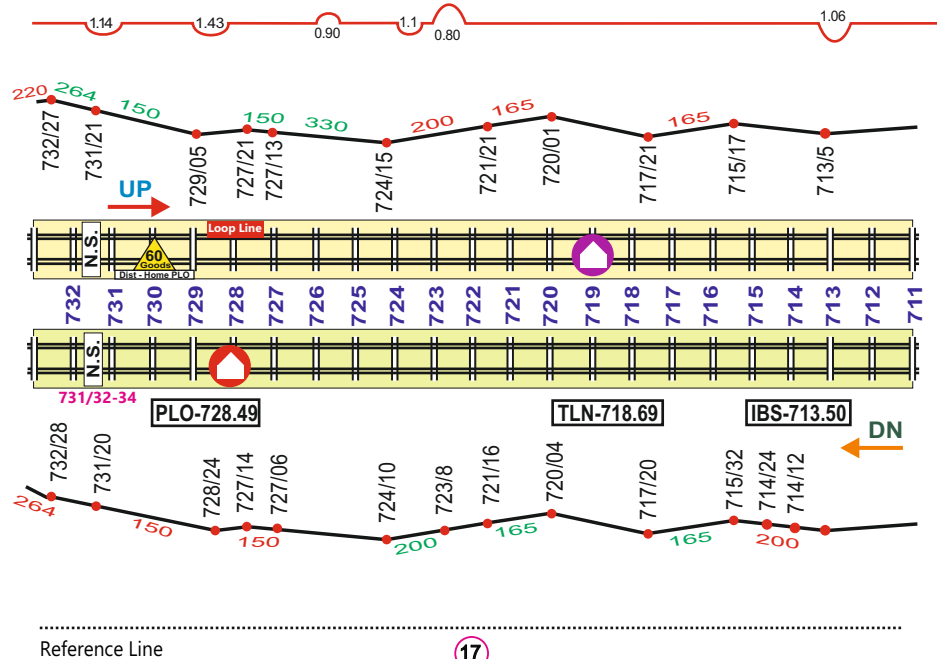
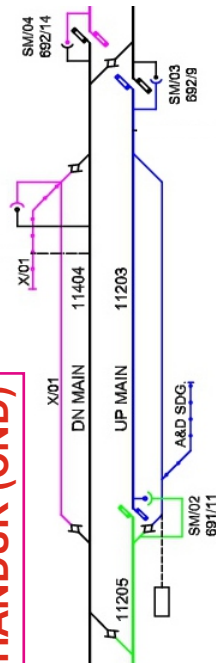

MALKHED (MLR)

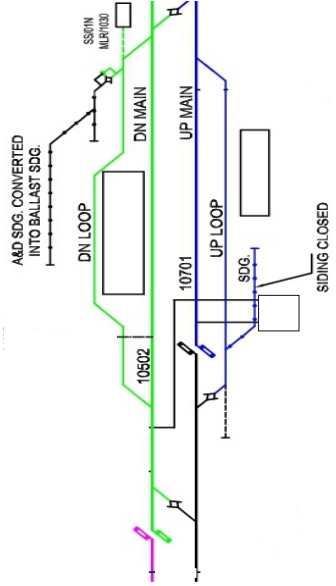

TIMTALA (TMT)

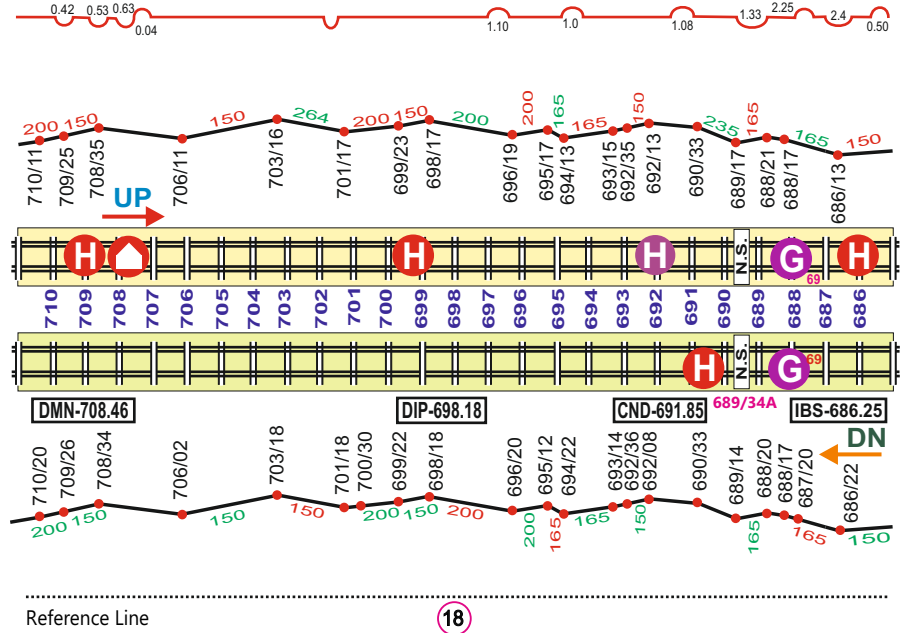
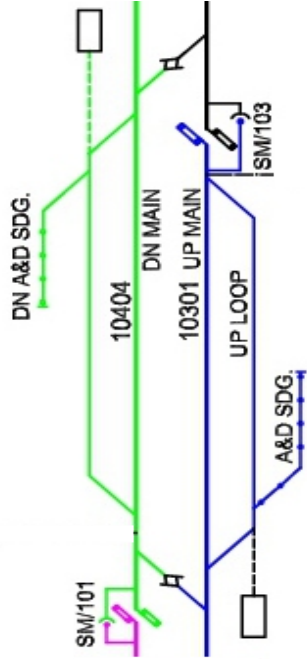

Reference Line

18

BADNERA (BD)

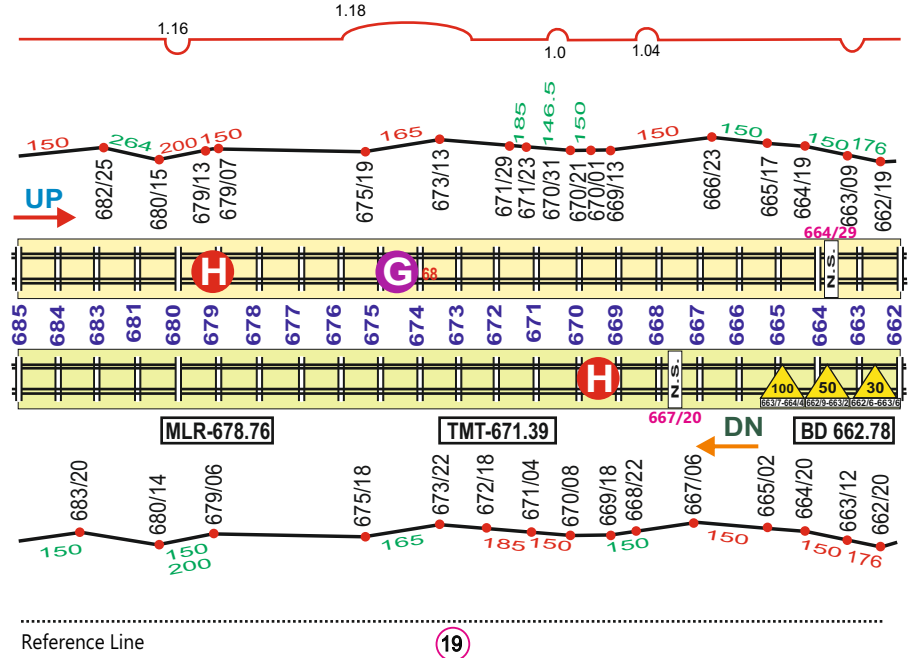
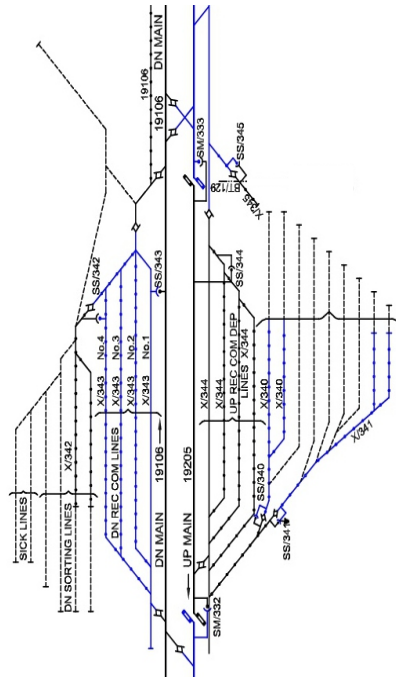
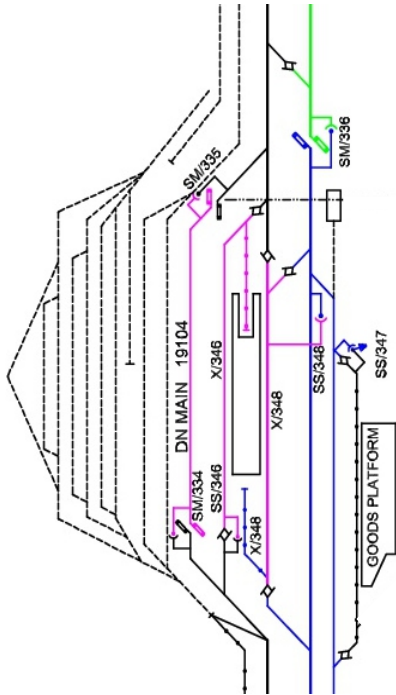

Designed & Prepared by - V K Gupta, CLI/NGP

Load – Table (NGP – AMLA)

(Banking Engine required between TEO - CCD)

| Stock | Loco Type | No B.E. | 1 B.E. | 2 B.E. |
|-------|----------------------------|-------------|-------------|-----------------|
| RB/AB | WAG-5/ WDM-2/ WDG-3A | Upto 1150 T | 1150-2400 T | Above 2400 T |
| | WAG-7/9, WDG-4 | Upto 1500 T | 1500-2500 T | Above 2500 T |

Load – Table (AMLA - NGP)

(Assisting Engine DBR required between CCD - TEO)

| Stock | Loco Type | No B.E. | 1 B.E. | 2 B.E. |
|-------|----------------------------|-------------|-------------|-----------------|
| RB/AB | WAG-5/ WDM-2/ WDG-3A | Upto 1150 T | 1150-2400 T | Above 2400 T |
| | WAG-7/9, WDG-4 | Upto 1500 T | 1500-2500 T | Above 2500 T |



NGP - AMLA - NGP

Length : 167 Kms

| | Section | Ruling Gradient | Length |
|----|------------|-----------------|----------|
| UP | TEP - CCD | 1/70 | 4.70 Kms |
| DN | AMLA - JKR | 1/150 | 5.90 Kms |

NAGPUR (NGP)



GODHANI (GNQ)

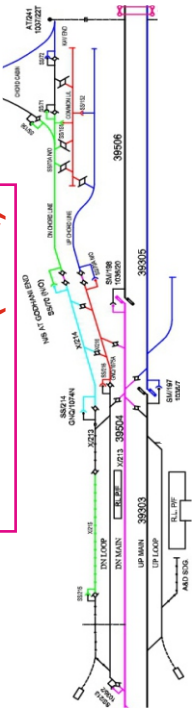

BHARATWADA (BWRA)

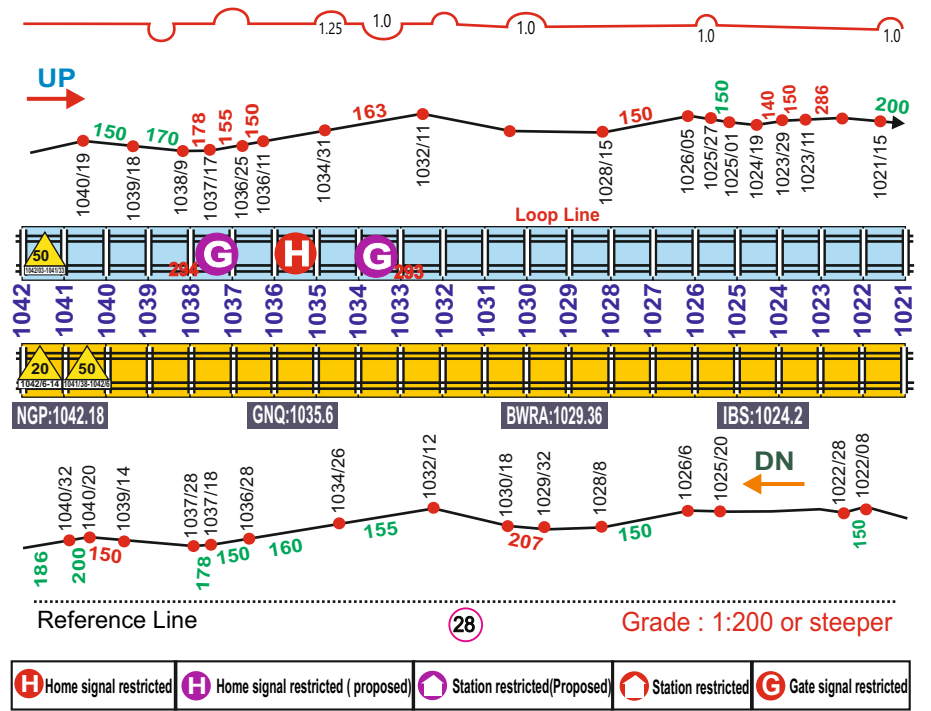
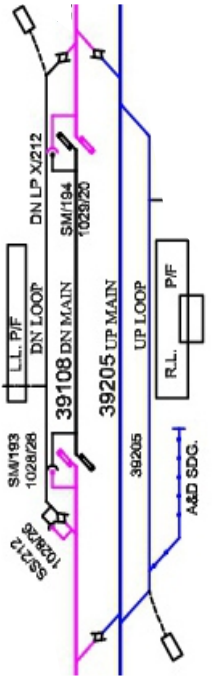

KALMESHWAR (KSWR)

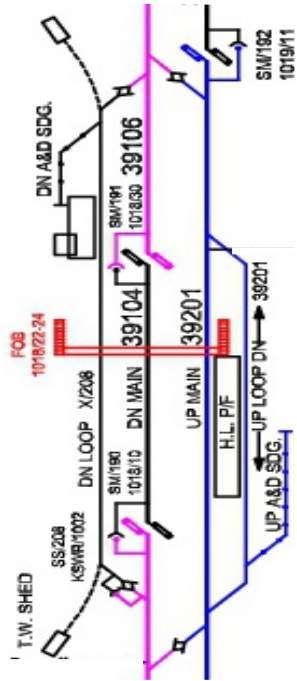

KOHLI (KOHL)

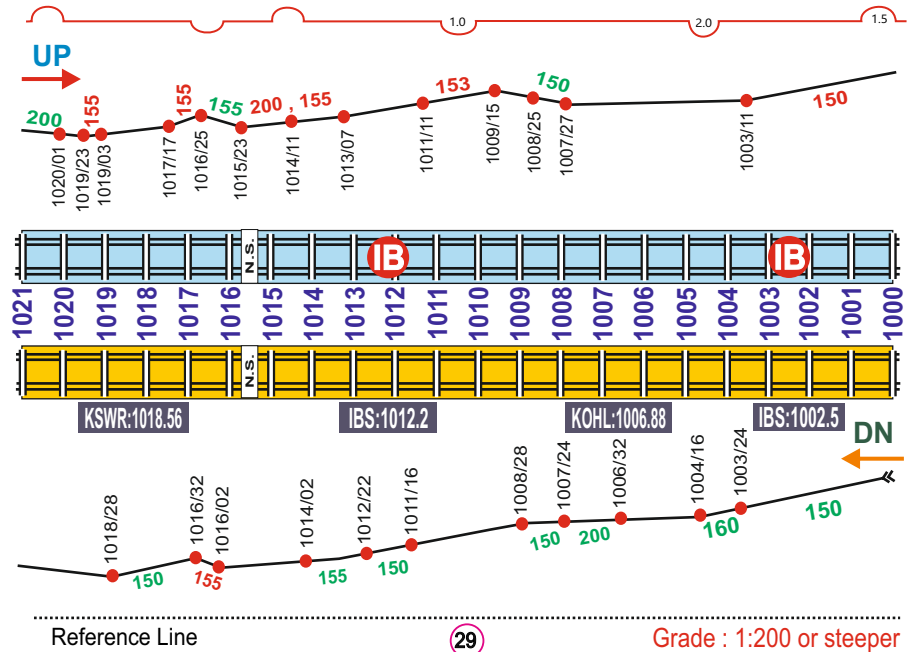
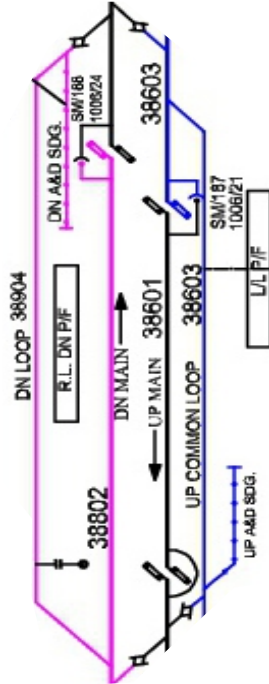

SONKHAMB (SNKB)

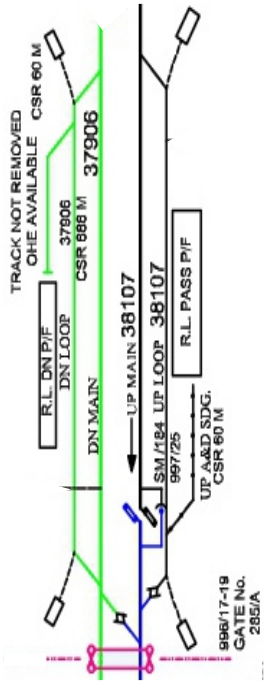

METPANJARA (MER)

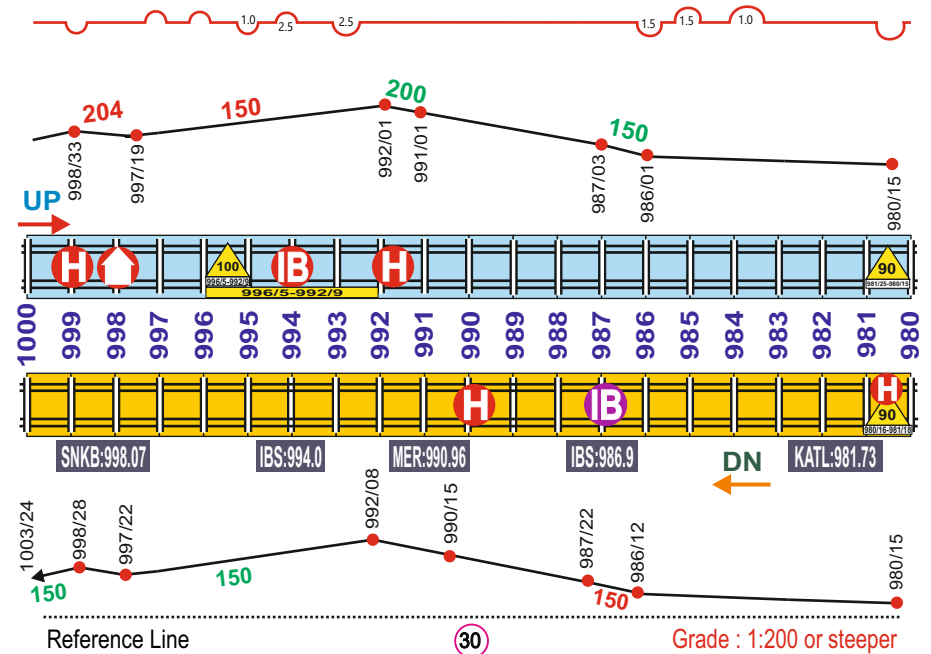
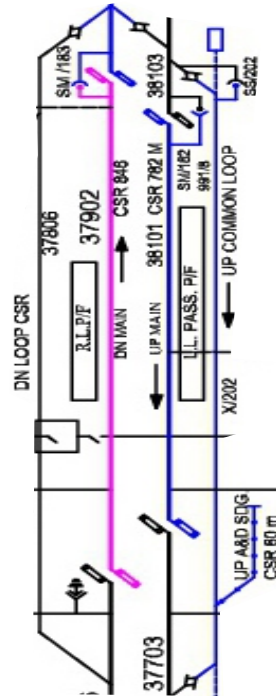

KATOL (KATL)

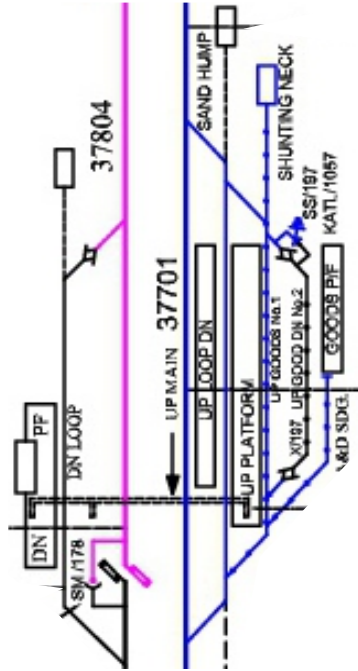

KALAMBHA (KLBA)

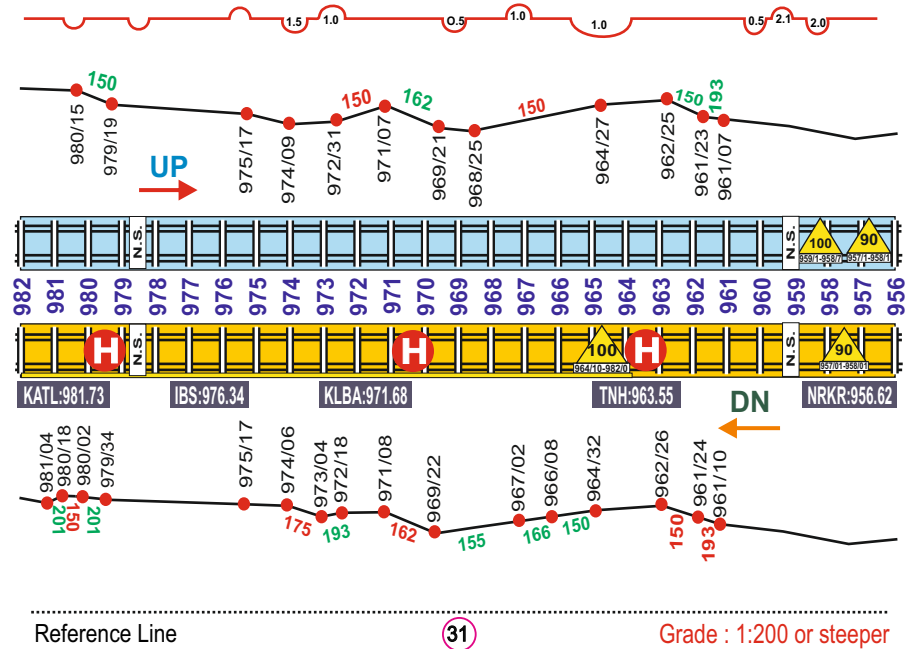
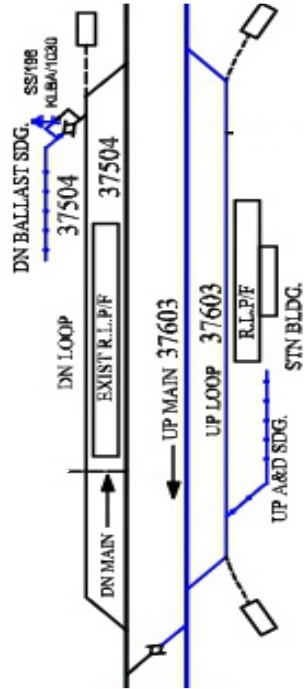

NARKHED (NRKR)

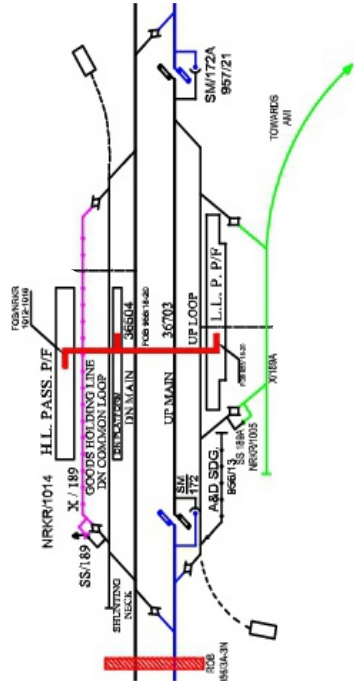

PANDURNA (PAR)

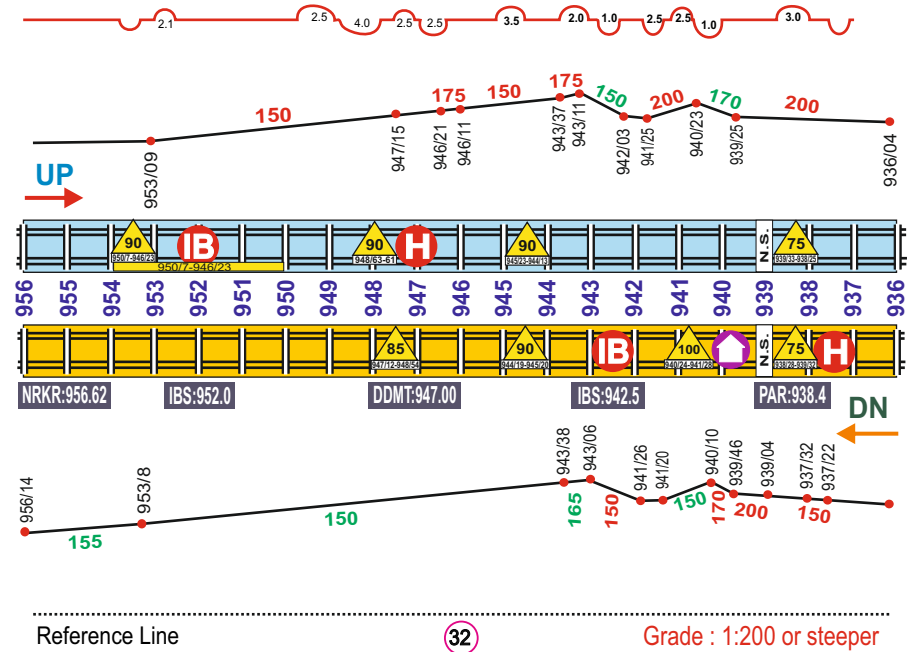
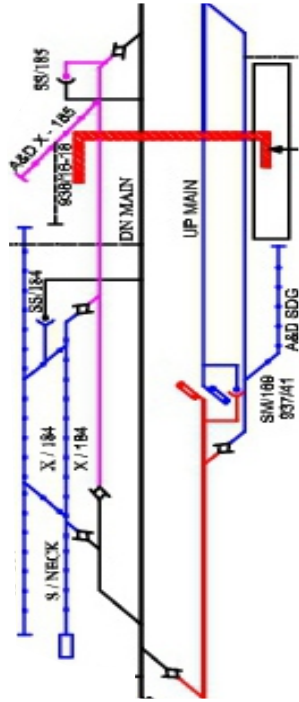

32

Grade : 1:200 or steeper

TEEGAON (TEO)

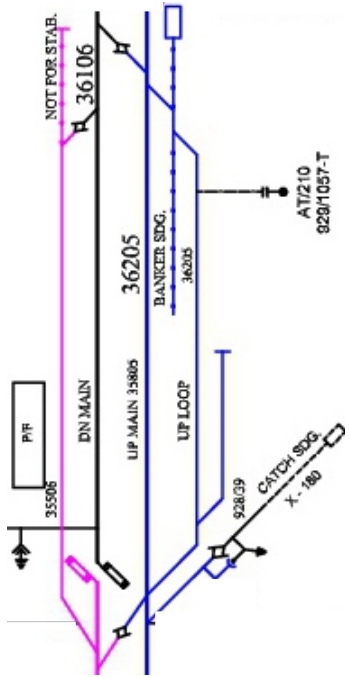

GHUDANKHAPA (GDKP)

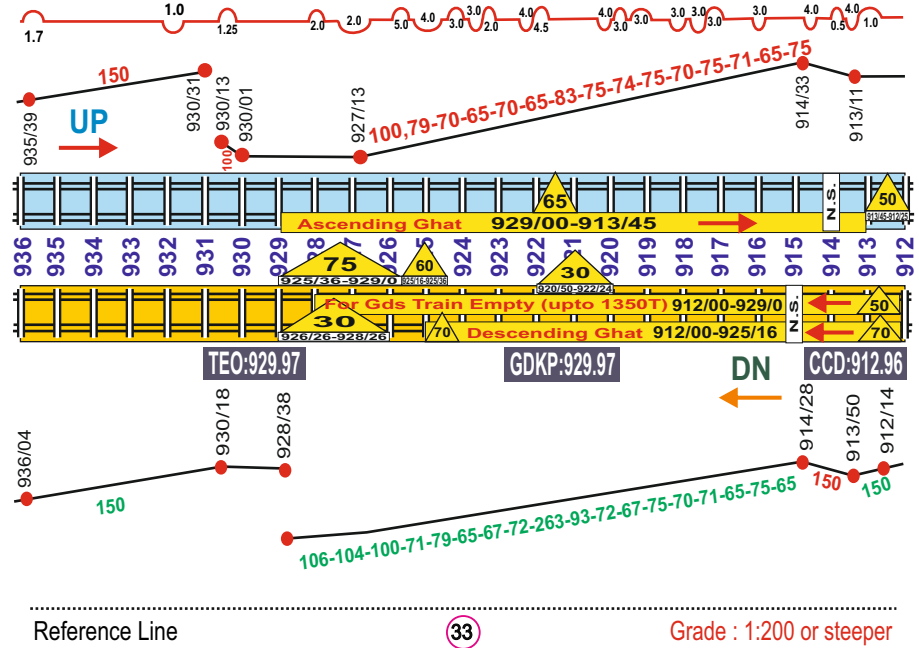
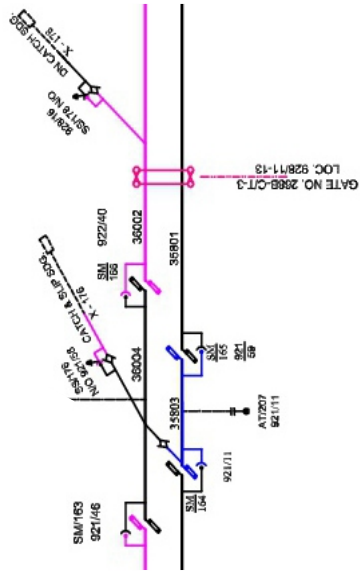

CHICHONDA (CCD)

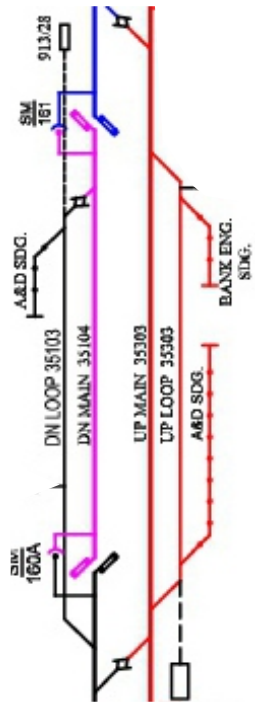

MULTAI (MTY)

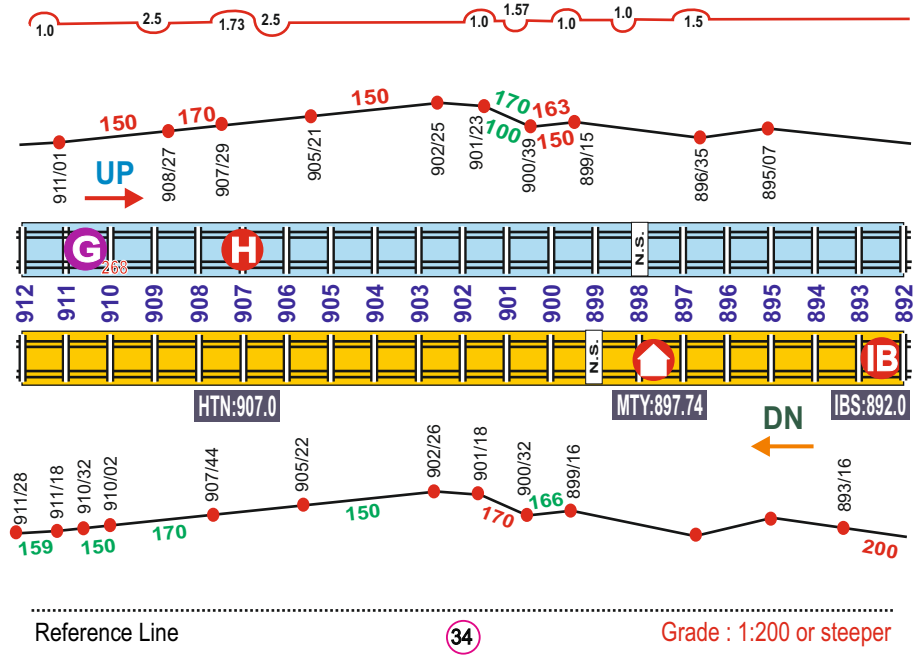
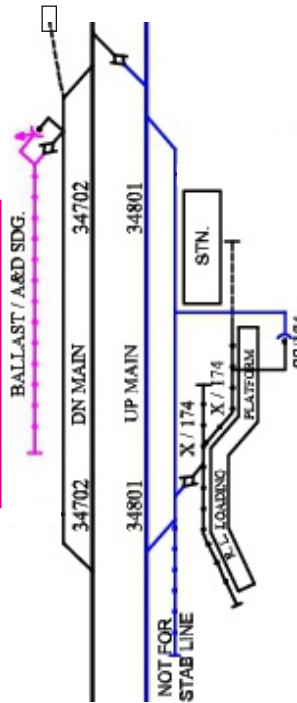



AMLA - CWA - AMLA

Single Line

Length : 113.47 Kms

| | Section | Ruling Gradient | Length |
|----|------------|-----------------|----------|
| DN | JNO - PCLI | 1/50 | 0.54 Kms |
| UP | PUX - IKR | 1/70 | 0.08 Kms |

Note: In PUX-CWA section bet. Km 961/28-989/30 MPS 90 Km/h & rest of the section 50 Km/h

Designed & Prepared by - V K Gupta, CLI/NGP

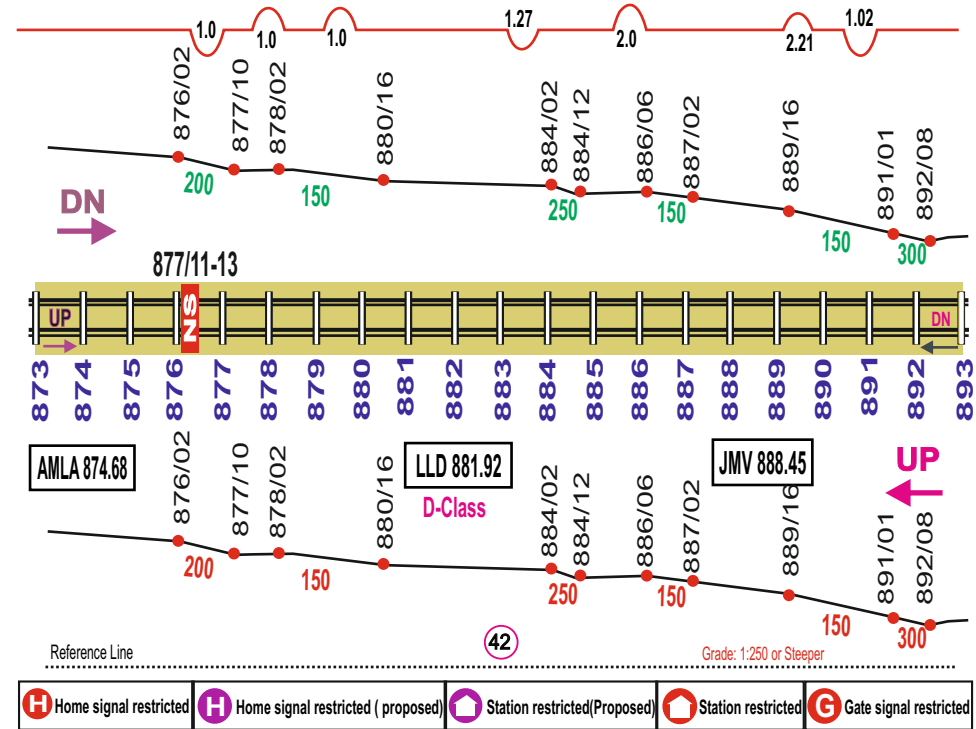

JAMBARA (JMV)

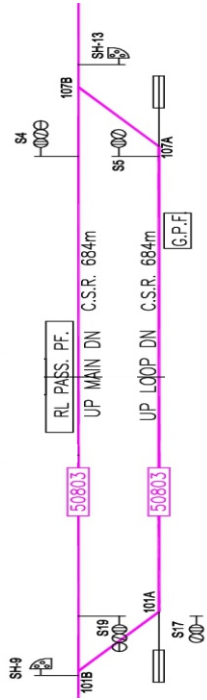

BORDHAI (BXY)

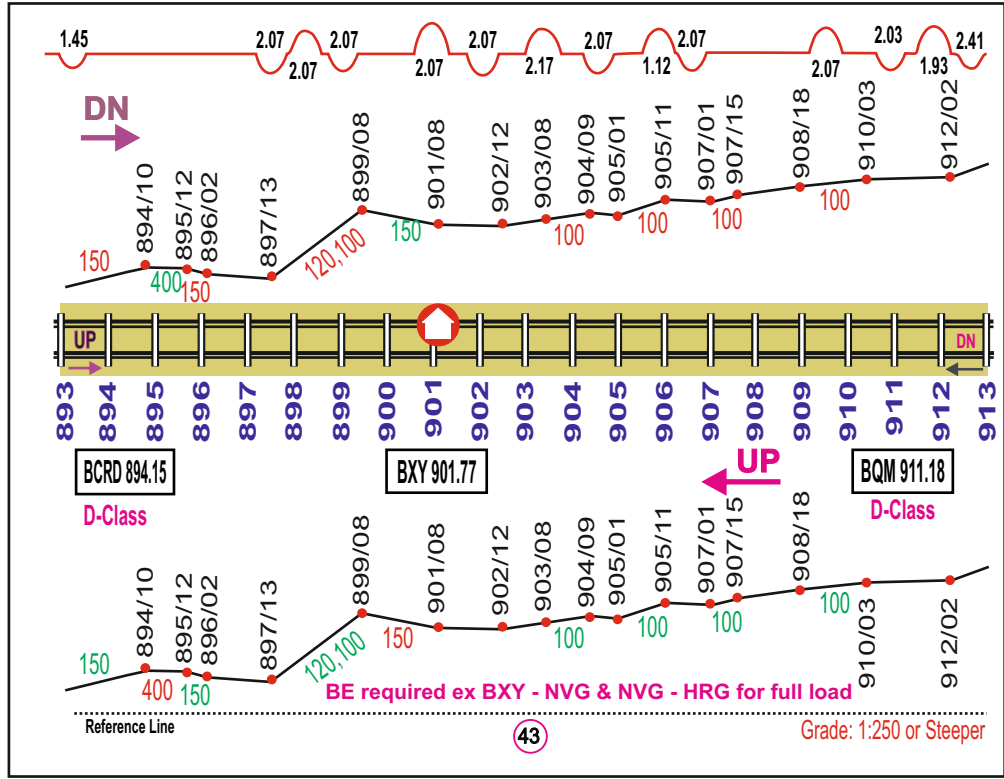
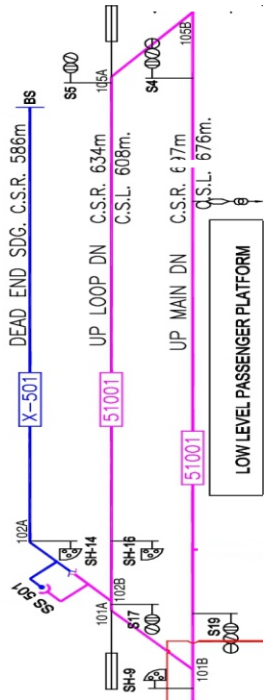

JUNNARDEO (JNO)

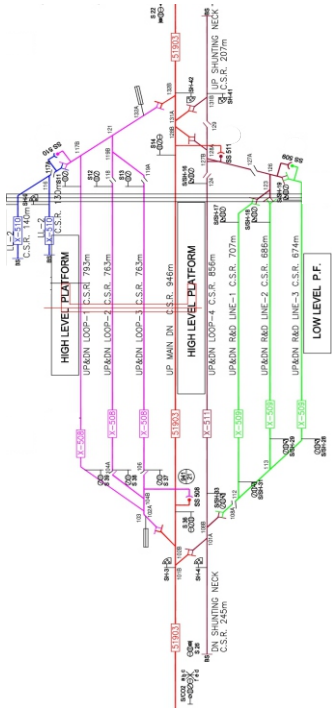

PALACHAURI (PCLI)

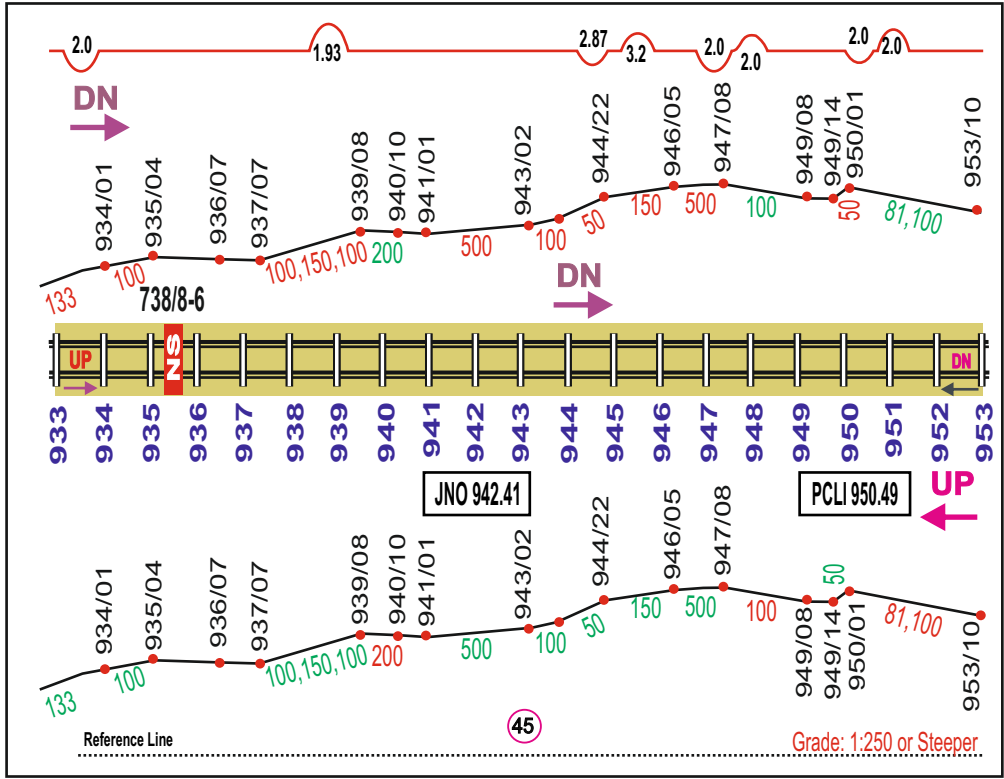
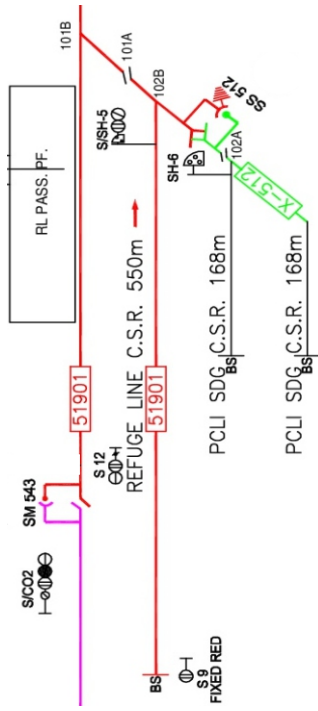

KHIRSADOH (KUX)

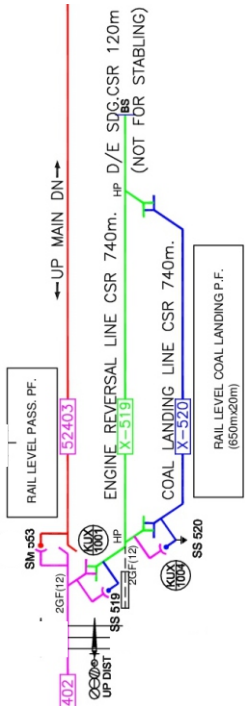

CHHINDWADA (CWA)

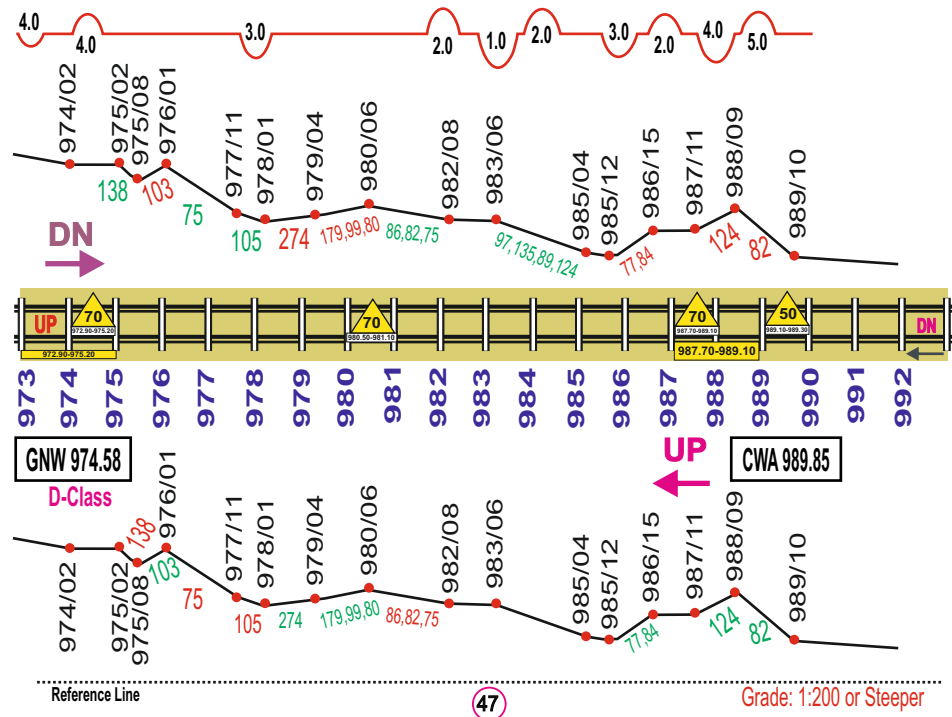
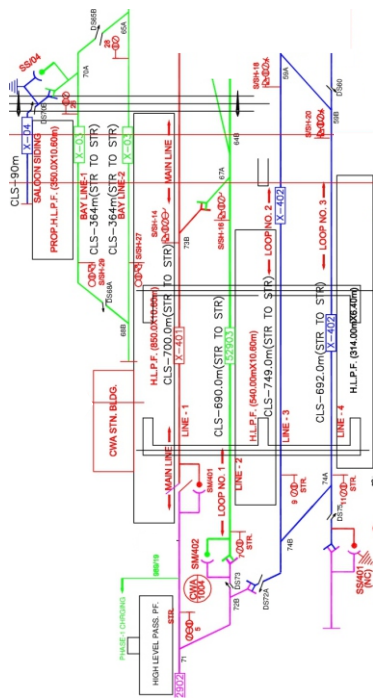

MJRI-WANI-PMKT-MJRI

Single Line

Length: 79.44 KMS.

| | Section | Ruling Gradient | Length |
|----|-----------|-----------------|----------|
| UP | MJRI-PMKT | 1/200 | 0.90 KM. |
| DN | PMKT-MJRI | 1/135 | 1.00 KM. |

Permanent Speed Restriction

| SN | Section | Kms | SR Kmph | Remarks |
|----|-----------|---------------|------------|--|
| UP | MJRI-WANI | 842.00-855.07 | 50 | M/Exp, Pass, Empty/ Loaded Goods Trains |
| | WANI-PMKT | 855.07-922.77 | 50 | M/Exp, Pass, Empty/ Loaded Goods Trains |

- V. K. Gupta, CLI/NGP

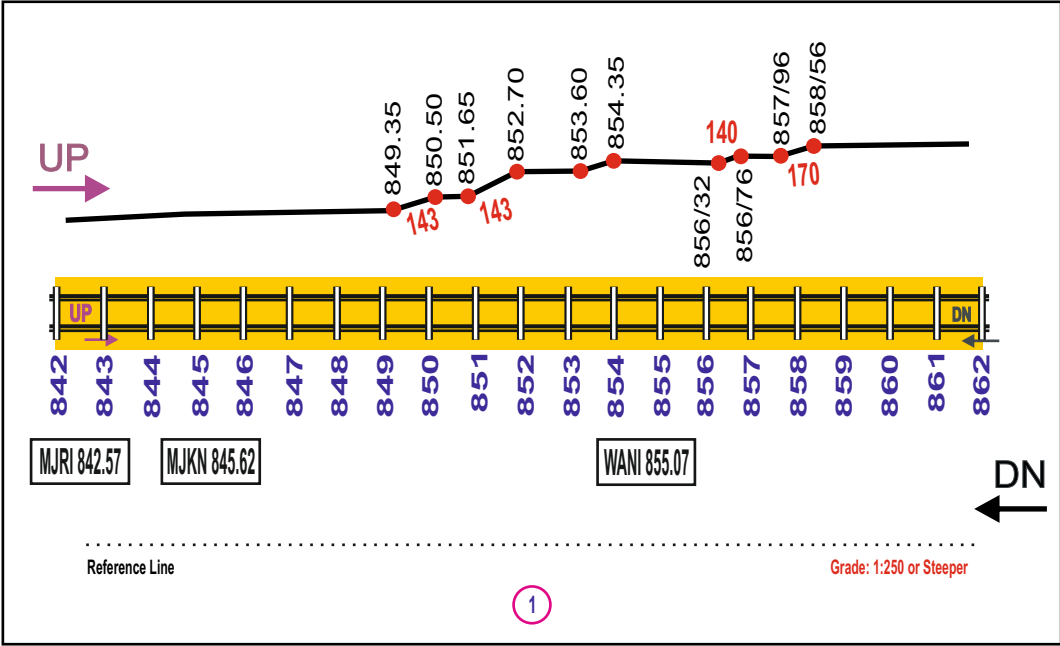

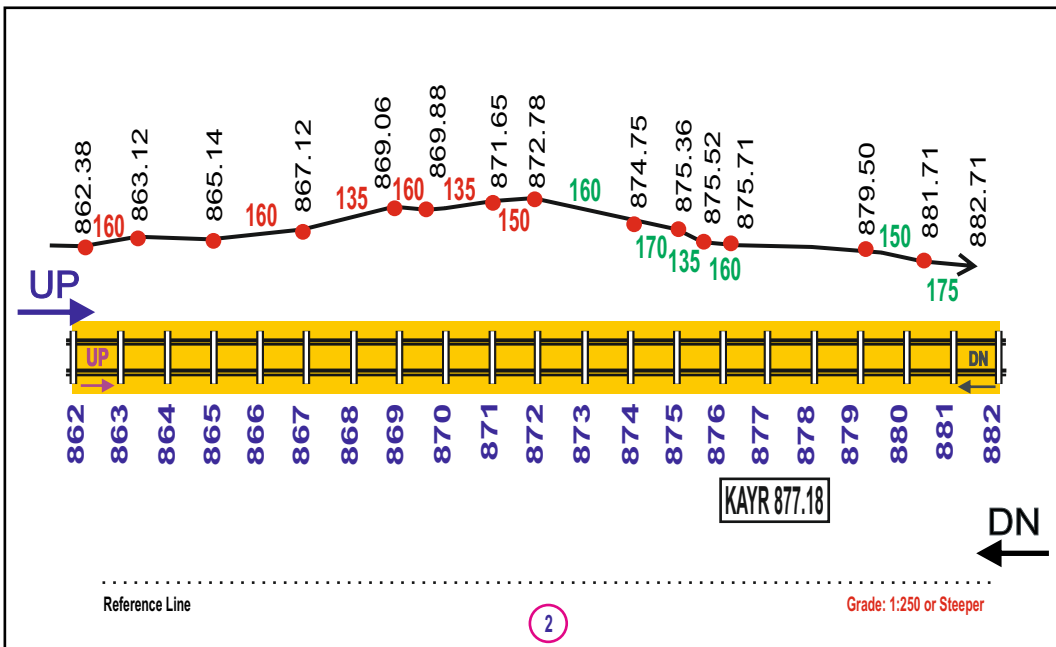

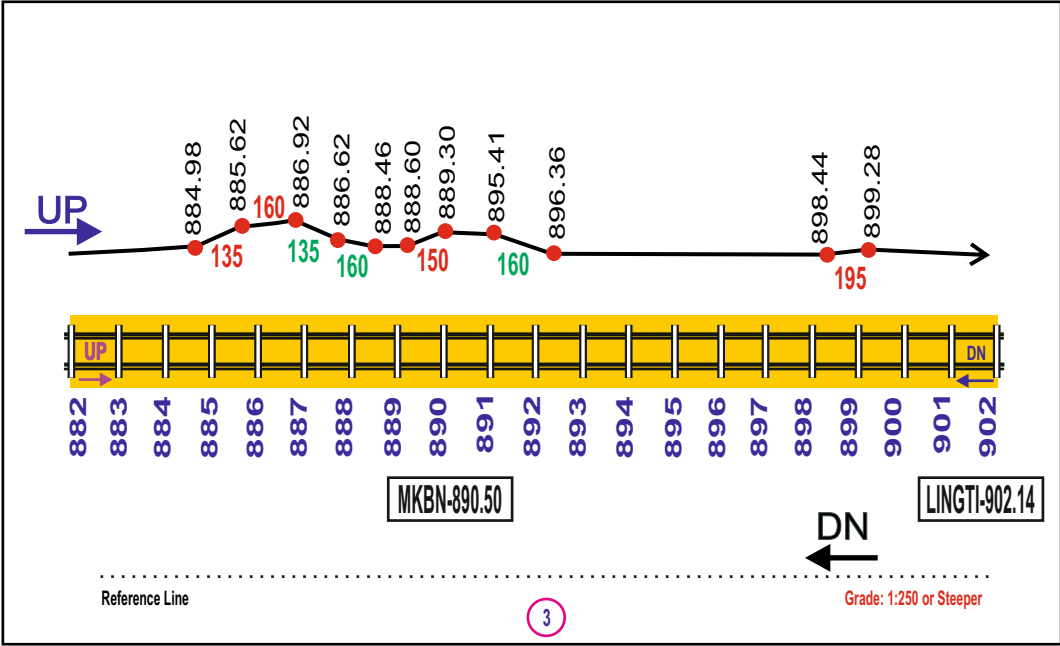

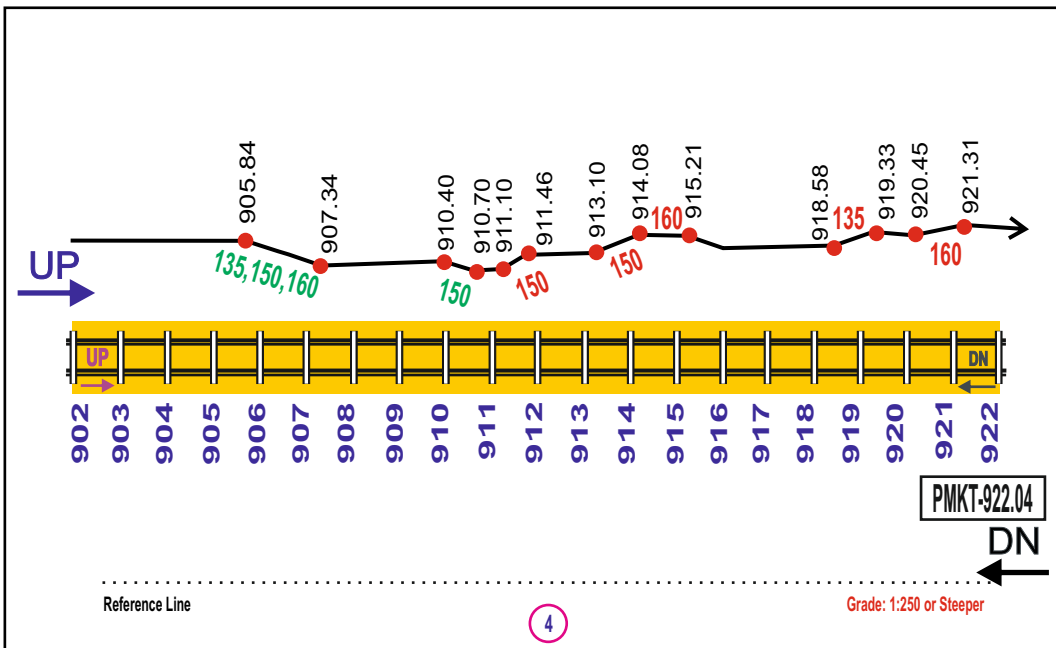

Load – Table (ET – AMLA)

(Banking Engine required between DHQ-MJY)

| Stock | Loco Type | No B.E. | 1 B.E. | 2 B.E. |
|-------|----------------------------|-------------|-------------|-----------------|
| RB/AB | WAG-5/ WDM-2/ WDG-3A | Upto 1150 T | 1150-2400 T | Above 2400 T |
| | WAG-7/9, WDG-4 | Upto 1500 T | 1500-2500 T | Above 2500 T |

Load – Table (AMLA - ET)

(Assisting Engine DBR required between MJY-DHQ)

| Stock | Loco Type | No B.E. | 1 B.E. | 2 B.E. |
|-------|----------------------------|-------------|-------------|-----------------|
| RB | WAG-5/ WDM-2/ WDG-3A | Upto 1150 T | 1150-2400 T | Above 2400 T |
| AB | WAG-5/ WDM-2/ WDG-3A | Upto 1500 T | 1500-2500 T | Above 2500 T |
| | WAG-7/9, WDG-4 | Upto 1150 T | 1150-2850 T | Above 2850 T |



AMLA - ET - AMLA

Length : 130 Kms

| | Section | Ruling Gradient | Length |
|----|-----------|-----------------|----------|
| UP | DOH - POX | 1/175 | 5.51 Kms |
| DN | DHQ - MJY | 1/60 | 0.89 Kms |

Designed & Prepared by - V K Gupta, CLI/NGP

BARSALI (BYS)

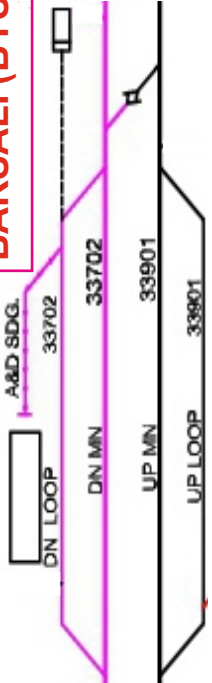

BETUL (BZU)

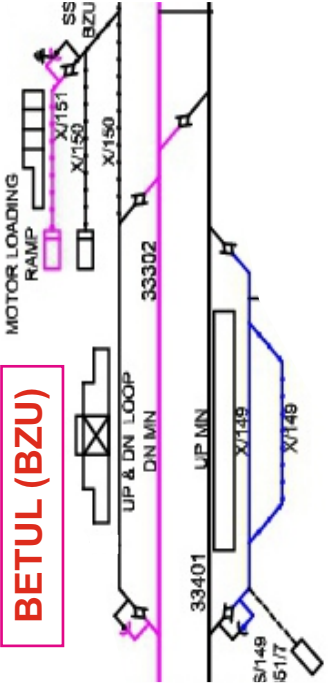

MARAMJHIRI (MJY)

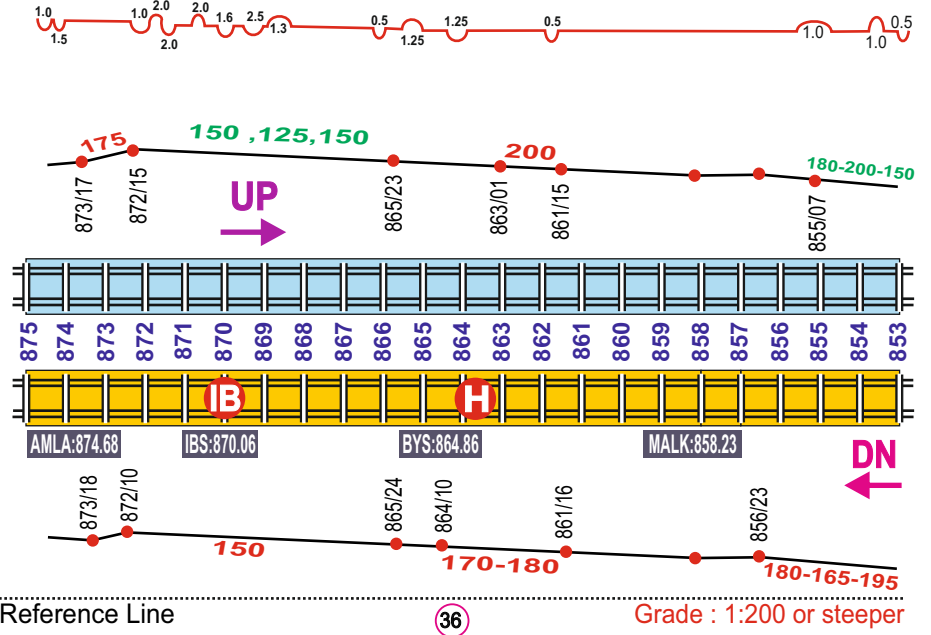
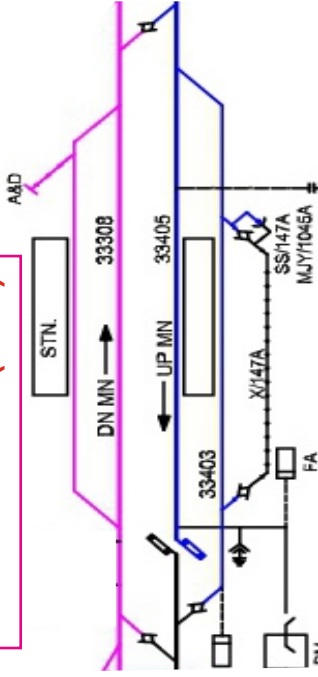

| | | | | |
|---------------------------------|--|---------------------------------------|-----------------------------|---------------------------------|
| H Home signal restricted | H Home signal restricted (proposed) | S Station restricted(Proposed) | S Station restricted | G Gate signal restricted |
|---------------------------------|--|---------------------------------------|-----------------------------|---------------------------------|

SARNI YARD

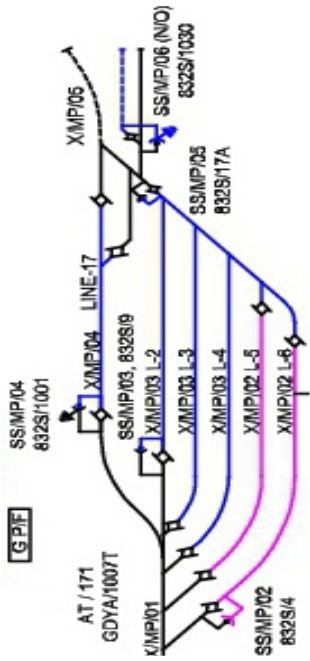

BARBATPUR (BBTR)

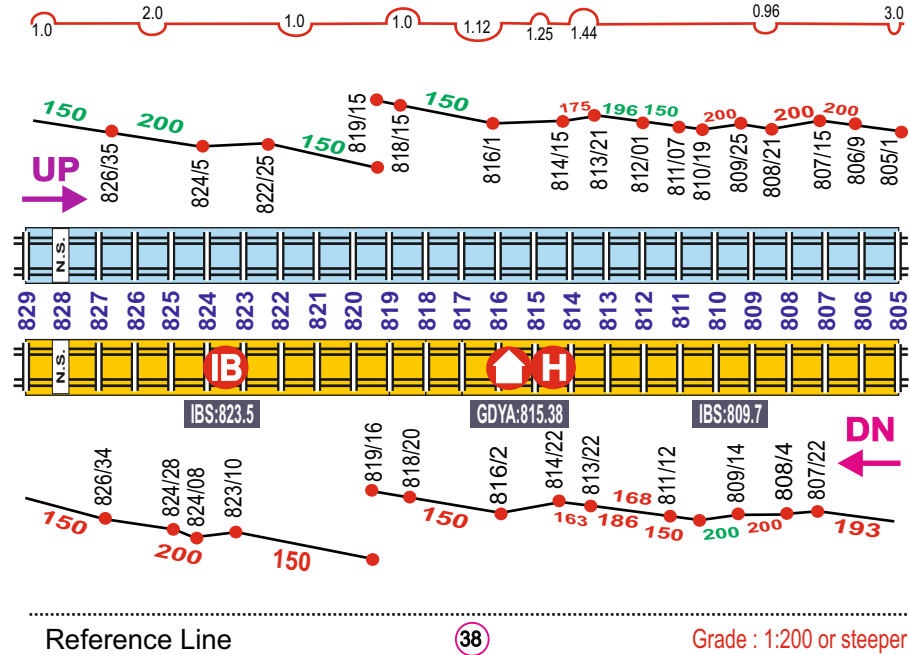
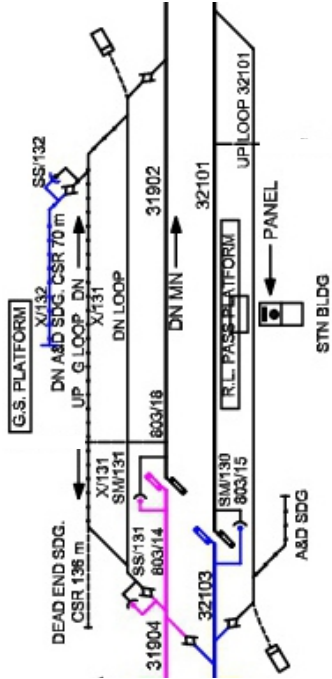

DHODRAMOHAR (DOH)

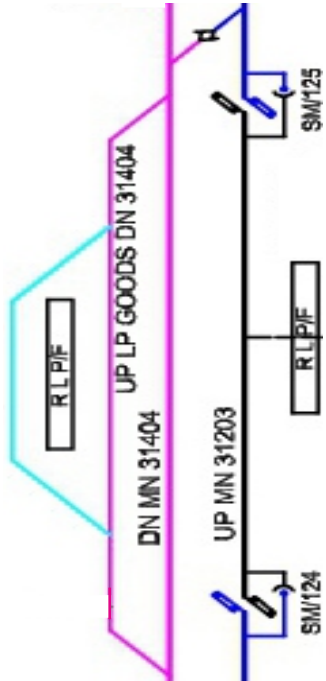

POLAPATHAR (POX)

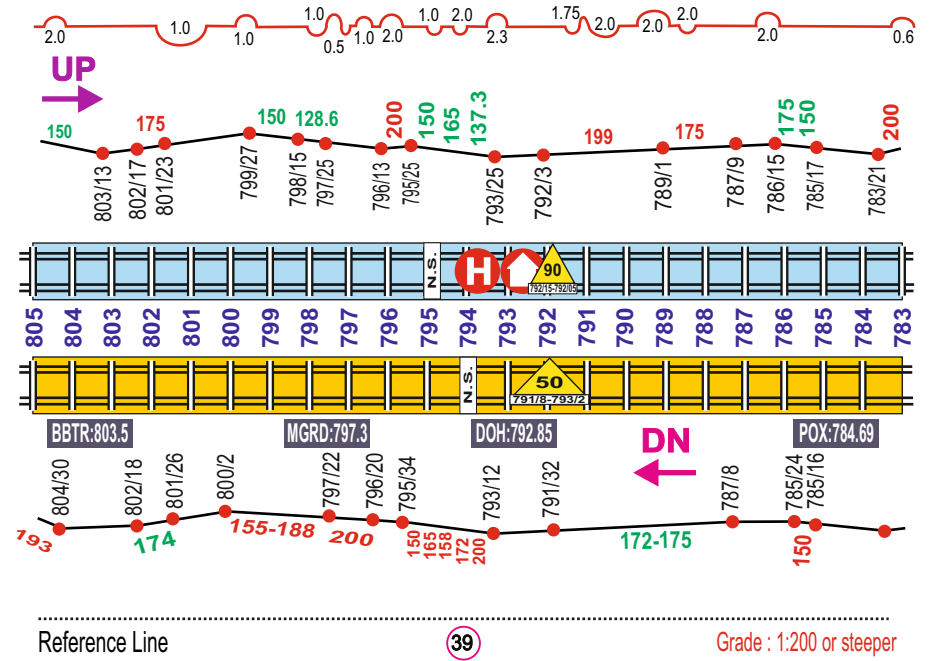
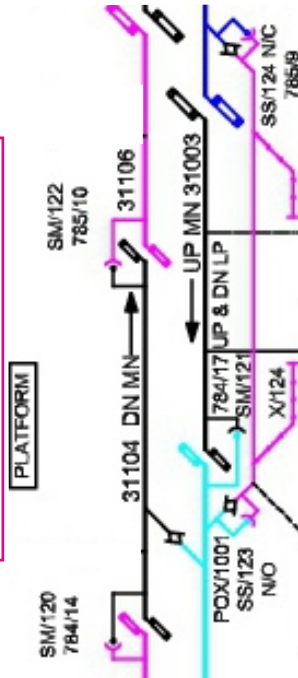

KALAAKHAR (KQE)

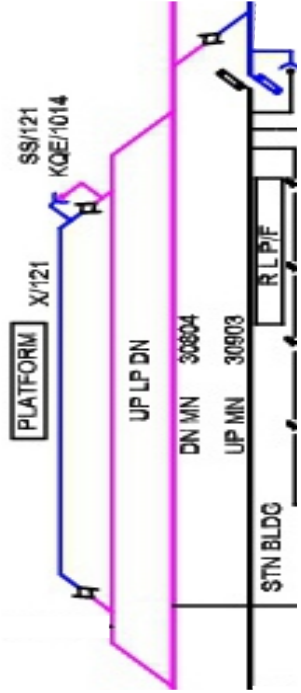

TAKU (TAKU)

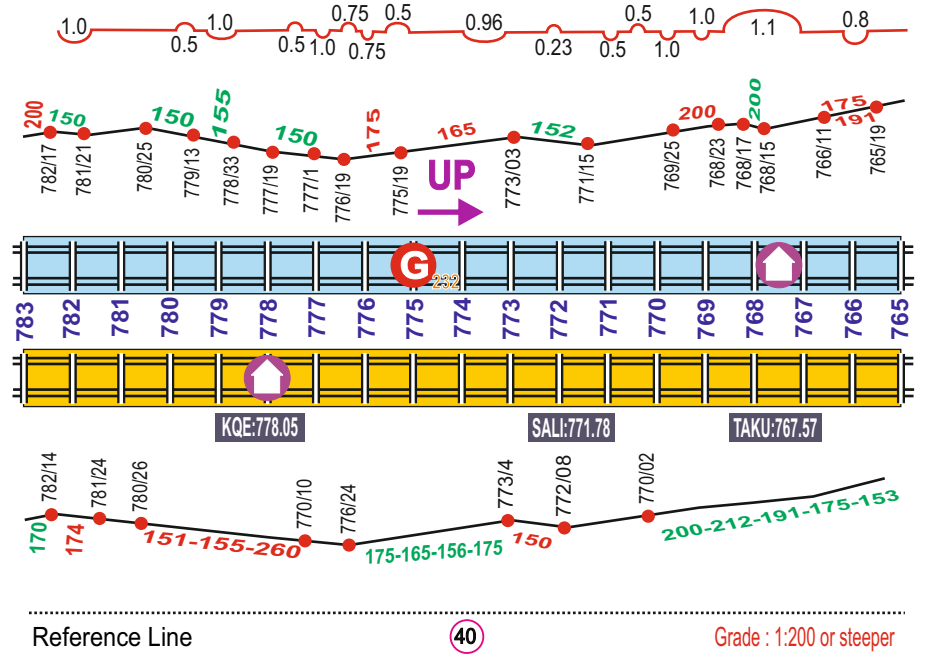
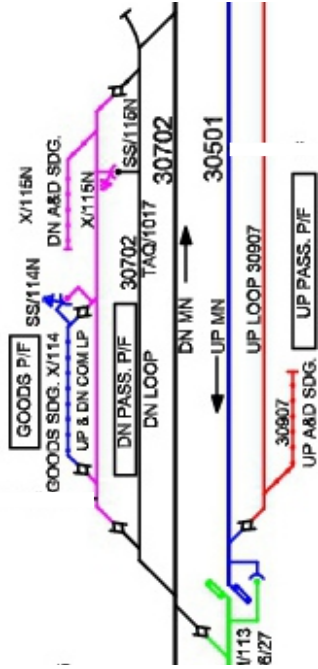

KIRATGARH (KRTH)

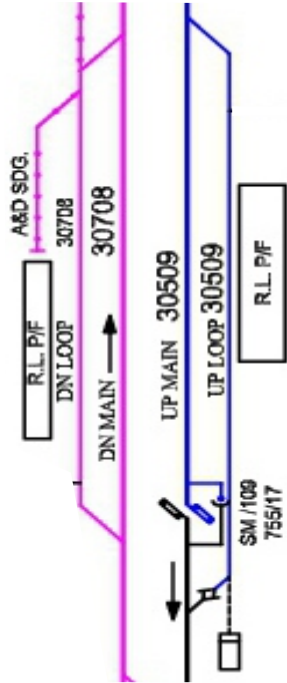

JUJHARPUR (JHP)

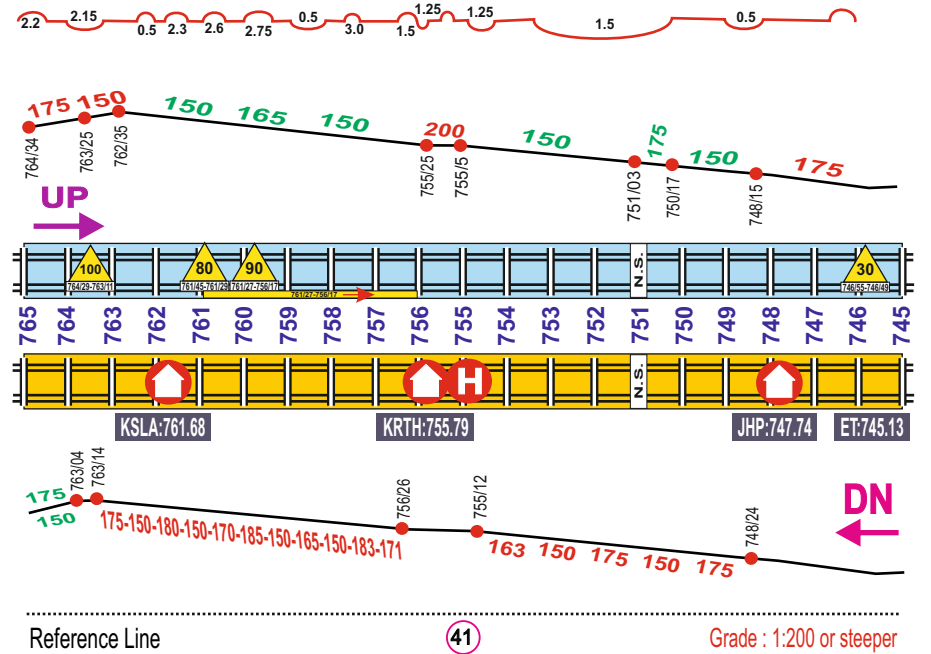
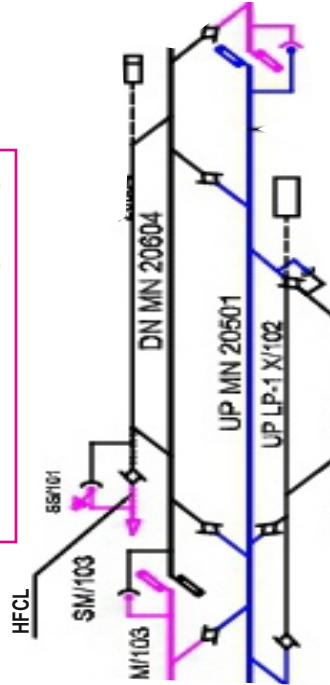

Designed & Prepared by - V K Gupta, CLI/NGP